

Robertson, Nathan

From: Jordan Smith [jordan.smith@natcap.gov.au] on behalf of WorksApproval [WorksApproval@natcap.gov.au]
Sent: Tuesday, 12 August 2014 3:57 PM
To: EPD, Customer Services
Subject: COMM-NCA-201425930-13/49 KINGSTON-01-EMAIL 1 OF 2

Dear Customer Services

The National Capital Authority has no comments to make on this development application

Regards

Jordan Smith | Planning Officer
National Capital Authority

 (02) 6271 2862 |  6273 4427

National Capital Authority | Treasury Building, King Edward Terrace, PARKES ACT 2600
GPO Box 373, CANBERRA ACT 2601 |  www.nationalcapital.gov.au | Twitter: @NCA_Media

 Please consider our environmental footprint before printing this e-mail

From: EPD, Customer Services [<mailto:EPDCustomerServices@act.gov.au>]
Sent: Thursday, 24 July 2014 2:38 PM
To: WorksApproval
Subject: REFERRAL-NCA-201425930-13/49 KINGSTON-01-EMAIL 1 OF 2

DEVELOPMENT APPLICATION NO: 201425930
BLOCK: 13 SECTION: 49 DIVISION: KINGSTON

NOTES:

Description - COMMERCIAL - Proposed demolition of the existing switch room down to existing slab level.

Pursuant to Section 148(1) of the Planning and Development Act 2007 the ACT Planning and Land Authority requests that you consider the abovementioned development application and provide any written advice no later than 15 working days after the date of this notice **(14/08/2014)** In accordance with Section 150 of the Planning and Development Act 2007 If advice is not received within the prescribed time it will be taken that you have supported the application.

Please forward any written advice via email to Customer Services - ESDDcustomerservices@act.gov.au

Please use the following format in the subject line of the email when providing advice:
COMM-Agency Name-20080XXXX-Block XX Section XX SuburbXXXX-01
Example: COMM-Heritage-200801234-Block 10 Section 10 Dickson-01

Regards

Customer Services

Phone 02 6207 1923

Client Services Branch | Environment and Sustainable Development | ACT Government
Dame Pattie Menzies House, 16 Challis Street, Dickson | GPO Box 1908 Canberra ACT 2601
www.actpla.act.gov.au | ESDDcustomerservices@act.gov.au

This email, and any attachments, may be confidential and also privileged. If you are not the intended recipient, please notify the sender and delete all copies of this transmission along with any attachments immediately. You should not copy or use it for any purpose, nor disclose its contents to any other person.

Robertson, Nathan

From: EPD, Customer Services on behalf of ESDD, Customer Services
Sent: Thursday, 24 July 2014 2:44 PM
To: Whitney, David
Subject: REFERRAL-NCA-201425930-13/49 KINGSTON-01-EMAIL 1 OF 2
Attachments: SITE-201425930-DEMOLITION PLAN-01.pdf; SURVEY-201425930-SURVEY-01.pdf; APP-201425930-03.pdf; APPOINT-201425930-01.pdf; MISC-201425930-HERITAGE-03.pdf; MISC-201425930-HERITAGE-04.pdf; MISC-201425930-STATEMENT OF HERITAGE-01.pdf; SCRITERIA-201425930-01.pdf; SUPP-1948 Switchroom Asbestos Survey 2010.pdf; WASTE-201425930-01.pdf

DEVELOPMENT APPLICATION NO: 201425930
BLOCK: 13 SECTION: 49 DIVISION: KINGSTON

Description - COMMERCIAL - Proposed demolition of the existing switch room down to existing slab level.

Pursuant to Section 148(1) of the Planning and Development Act 2007 the ACT Planning and Land Authority requests that you consider the abovementioned development application and provide any written advice no later than 15 working days after the date of this notice (**14/08/2014**) In accordance with Section 150 of the Planning and Development Act 2007 If advice is not received within the prescribed time it will be taken that you have supported the application.

Please forward any written advice via email to Customer Services - ESDDcustomerservices@act.gov.au

Please use the following format in the subject line of the email when providing advice:
COMM-Agency Name-20080XXXX-Block XX Section XX SuburbXXXXX-01
Example: COMM-Heritage-200801234-Block 10 Section 10 Dickson-01

Regards

Customer Services

Phone 02 6207 1923

Client Services Branch | Environment and Sustainable Development | ACT Government
Dame Pattie Menzies House, 16 Challis Street, Dickson | GPO Box 1908 Canberra ACT 2601
www.actpla.act.gov.au | ESDDcustomerservices@act.gov.au

Robertson, Nathan

From: EPD, Customer Services on behalf of ESDD, Customer Services
Sent: Thursday, 24 July 2014 2:45 PM
To: Whitney, David
Subject: REFERRAL-NCA-201425930-13/49 KINGSTON-01-EMAIL 2 OF 2
Attachments: MISC-201425930-HERITAGE-01.pdf; MISC-201425930-HERITAGE-02.pdf; MISC-201425930-HERITAGE-05.pdf

DEVELOPMENT APPLICATION NO: 201425930
BLOCK: 13 SECTION: 49 DIVISION: KINGSTON

NOTES:

Description - COMMERCIAL - Proposed demolition of the existing switch room down to existing slab level.

Pursuant to Section 148(1) of the Planning and Development Act 2007 the ACT Planning and Land Authority requests that you consider the abovementioned development application and provide any written advice no later than 15 working days after the date of this notice (**14/08/2014**) In accordance with Section 150 of the Planning and Development Act 2007 If advice is not received within the prescribed time it will be taken that you have supported the application.

Please forward any written advice via email to Customer Services - ESDDcustomerservices@act.gov.au

Please use the following format in the subject line of the email when providing advice:
COMM-Agency Name-20080XXXX-Block XX Section XX SuburbXXXX-01
Example: COMM-Heritage-200801234-Block 10 Section 10 Dickson-01

Regards

Customer Services

Phone 02 6207 1923

Client Services Branch | Environment and Sustainable Development | ACT Government
Dame Pattie Menzies House, 16 Challis Street, Dickson | GPO Box 1908 Canberra ACT 2601
www.actpla.act.gov.au | ESDDcustomerservices@act.gov.au

Robertson, Nathan

From: EPD, Customer Services on behalf of ESDD, Customer Services
Sent: Thursday, 24 July 2014 2:29 PM
To: 'devapp@actewagl.com.au'
Subject: REFERRAL-ACTEW AGL-UTILITIES-201425930-13/49 KINGSTON-01-EMAIL 1 OF 2
Attachments: SITE-201425930-DEMOLITION PLAN-01.pdf; SURVEY-201425930-SURVEY-01.pdf; APP-201425930-03.pdf; APPOINT-201425930-01.pdf; MISC-201425930-HERITAGE-03.pdf; MISC-201425930-HERITAGE-04.pdf; MISC-201425930-STATEMENT OF HERITAGE-01.pdf; SCRITERIA-201425930-01.pdf; SUPP-1948 Switchroom Asbestos Survey 2010.pdf; WASTE-201425930-01.pdf

DEVELOPMENT APPLICATION NO: 201425930
BLOCK: 13 **SECTION:** 49 **DIVISION:** KINGSTON

NOTES:

Description - COMMERCIAL - Proposed demolition of the existing switch room down to existing slab level.

Pursuant to Section 148(1) of the Planning and Development Act 2007 the ACT Planning and Land Authority requests that you consider the abovementioned development application and provide any written advice no later than 15 working days after the date of this notice (**14/08/2014**) In accordance with Section 150 of the Planning and Development Act 2007 If advice is not received within the prescribed time it will be taken that you have supported the application.

Please forward any written advice via email to Customer Services - ESDDcustomerservices@act.gov.au

Please use the following format in the subject line of the email when providing advice:
COMM-Agency Name-20080XXXX-Block XX Section XX SuburbXXXXX-01
Example: COMM-Heritage-200801234-Block 10 Section 10 Dickson-01

Regards

Customer Services

Phone 02 6207 1923

Client Services Branch | Environment and Sustainable Development | ACT Government
Dame Pattie Menzies House, 16 Challis Street, Dickson | GPO Box 1908 Canberra ACT 2601
www.actpla.act.gov.au | ESDDcustomerservices@act.gov.au

Robertson, Nathan

From: EPD, Customer Services on behalf of ESDD, Customer Services
Sent: Thursday, 24 July 2014 2:31 PM
To: 'devapp@actewagl.com.au'
Subject: REFERRAL-ACTEW AGL-UTILITIES-201425930-13/49 KINGSTON-01-EMAIL 2 OF 2
Attachments: MISC-201425930-HERITAGE-01.pdf; MISC-201425930-HERITAGE-02.pdf;
MISC-201425930-HERITAGE-05.pdf

DEVELOPMENT APPLICATION NO: 201425930
BLOCK: 13 **SECTION:** 49 **DIVISION:** KINGSTON

NOTES:

Description - COMMERCIAL - Proposed demolition of the existing switch room down to existing slab level.

Pursuant to Section 148(1) of the Planning and Development Act 2007 the ACT Planning and Land Authority requests that you consider the abovementioned development application and provide any written advice no later than 15 working days after the date of this notice (**14/08/2014**) In accordance with Section 150 of the Planning and Development Act 2007 If advice is not received within the prescribed time it will be taken that you have supported the application.

Please forward any written advice via email to Customer Services – ESDDcustomerservices@act.gov.au

Please use the following format in the subject line of the email when providing advice:
COMM-Agency Name-20080XXXX-Block XX Section XX SuburbXXXXX-01
Example: COMM-Heritage-200801234-Block 10 Section 10 Dickson-01

Regards

Customer Services

Phone 02 6207 1923

Client Services Branch | Environment and Sustainable Development | ACT Government
Dame Pattie Menzies House, 16 Challis Street, Dickson | GPO Box 1908 Canberra ACT 2601
www.actpla.act.gov.au | ESDDcustomerservices@act.gov.au

Robertson, Nathan

From: Elle Peters [Elle.Peters@jemena.com.au]
Sent: Friday, 25 July 2014 11:49 AM
To: EPD, Customer Services
Subject: ActewAGL - Notification of Building Application - Application ID : 201425930
Attachments: BA DA Conditional Approval Docs.pdf; document2014-07-25-114805.pdf

Your application has been assessed by ActewAGL and conditionally complies with our Gas Networks requirements.

Please find attached, your stamped plans together with a statement of compliance.

Separate compliance statements are required from other utilities (eg: electricity, water and sewerage, stormwater and communications).

Regards



This is a confidential message intended for the named recipient(s) only. The contents herein are privileged to the sender and the use thereof is restricted to the intended purpose. If you have received this e-mail in error, please do not use, disclose, distribute, copy, print or relay on this email. If receipt is in error, please advise the sender by reply email. Thank you.



Gas Networks

STATEMENT OF
CONDITIONAL COMPLIANCE

For Non-residential and High Rise Residential

Application N^o: 201425930 Drawings in set 1

Block: 13 Section: 49

Suburb: Kingston

This application has been assessed against legislation protecting ActewAGL's gas infrastructure and access to it.

This application is approved subject to compliance with the following conditions:

- The location and area allocated for gas regulating and metering equipment is to comply with ActewAGL standards. The following documents provide guidance:
Ref ActewAGL Document (attached): "Gas Metering Equipment – Prohibited Locations"
Ref ActewAGL Document (attached): "Gas Metering Equipment – In High Rise Buildings"
Ref ActewAGL Document (attached): "Gas Metering Equipment – Meter Set Enclosures"
- Development is to comply with minimum separation requirements to underground assets
 - 300mm minimum clearance from major plastic and steel gas mains and steel gas services
 - 150mm minimum clearance from other plastic gas mains and services
- A metering equipment upgrade may be required. A licensed gas fitter should verify loads and metering equipment capacities.
- If a meter relocation or service pipe relocation is required in order to comply with ActewAGL standards, please contact your gas retailer and book a meter relocation. Only people accredited by ActewAGL can carry out this work.
- Other:

Please note:

- **WARNING:** ActewAGL underground gas pipes may be in or adjacent to this block. ActewAGL Asset Location Advice may be required. Call 1100.
- Development and Building Applications will need to include any proposed ActewAGL works
- If ActewAGL approval conditions are not met, a breach of the law may result.
- Separate applications are required for water & sewerage, electricity and communication network services.
- Construction of unapproved works may result in action being taken to require the property owner to remove non-compliant structures and/or the property owner to fund rectification works on ActewAGL's gas network
- Any attached reticulation or servicing plan is preliminary only. Contact ActewAGL for final plans prior to the commencement of any construction activity

Signed.....[Signature].....Date 25/7/14.....

For further information please phone Steve Donnelly – Jemena 6203 0640

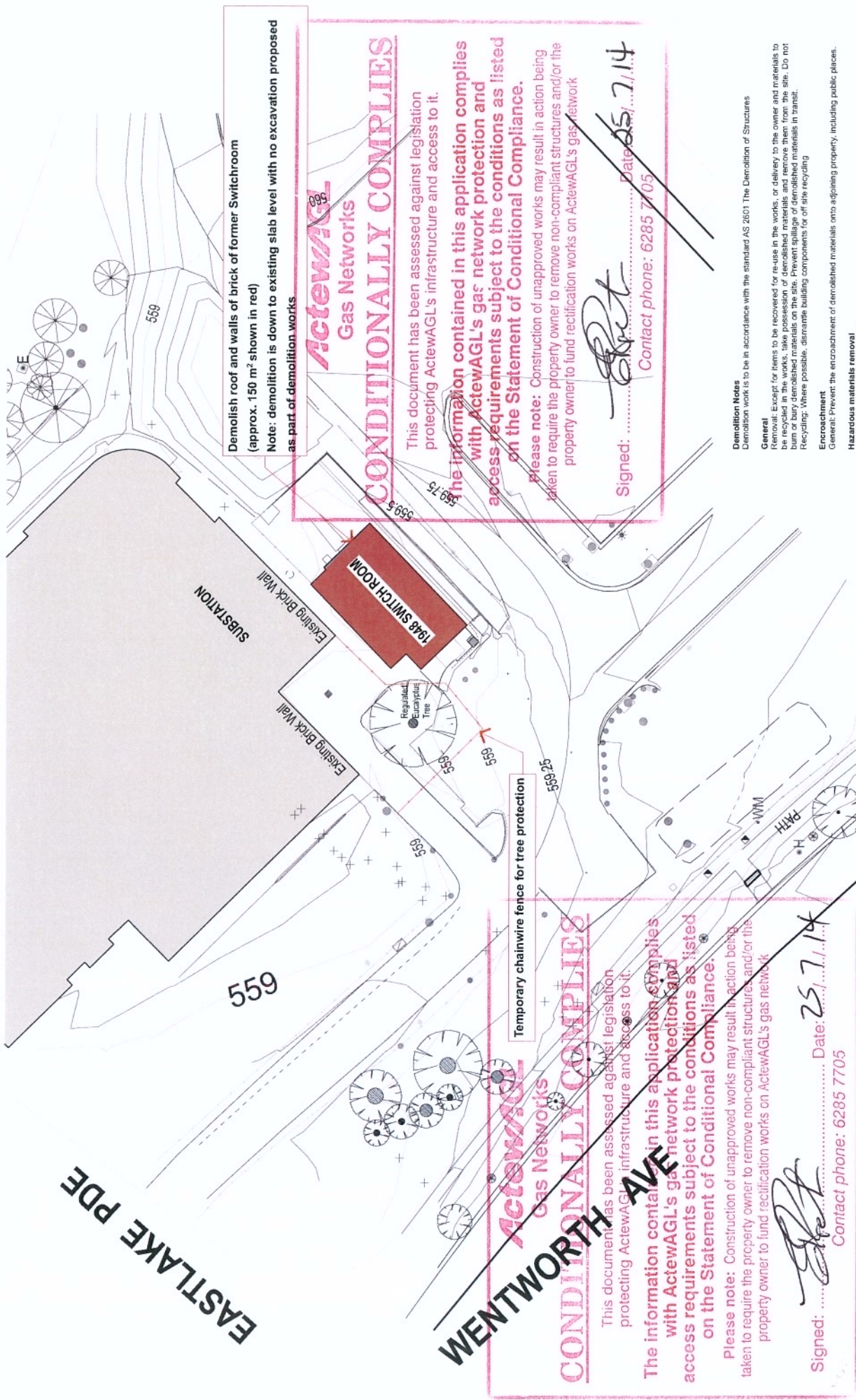

Demolish roof and walls of brick of former Switchroom (approx. 150 m² shown in red)
Note: demolition is down to existing slab level with no excavation proposed as part of demolition works

ActewAGL Gas Networks
CONDITIONALLY COMPLIES

This document has been assessed against legislation protecting ActewAGL's infrastructure and access to it.

The information contained in this application complies with ActewAGL's gas network protection and access requirements subject to the conditions as listed on the Statement of Conditional Compliance.

Please note: Construction of unapproved works may result in action being taken to require the property owner to remove non-compliant structures and/or the property owner to fund rectification works on ActewAGL's gas network

Signed: Date: 25/7/14
 Contact phone: 6285 7705

ActewAGL Gas Networks
CONDITIONALLY COMPLIES

This document has been assessed against legislation protecting ActewAGL's infrastructure and access to it.

The information contained in this application complies with ActewAGL's gas network protection and access requirements subject to the conditions as listed on the Statement of Conditional Compliance.

Please note: Construction of unapproved works may result in action being taken to require the property owner to remove non-compliant structures and/or the property owner to fund rectification works on ActewAGL's gas network

Signed: Date: 25/7/14
 Contact phone: 6285 7705

Demolition Notes
 Demolition work is to be in accordance with the standard AS 2601 The Demolition of Structures

General
 Removal: Except for items to be recovered for re-use in the works, or delivery to the owner and materials to be recycled, all materials, including hazardous materials, are to be removed from the site. Do not backfill, dump, discharge, or otherwise dispose of any materials in the site.
 Recycling: Where possible, dismantle building components for off site recycling

Encroachment
 General: Prevent the encroachment of demolished materials onto adjoining property, including public places.

Hazardous materials removal
 Standard: TO NS 2601 clause 1.6.2.

Landscape Management & Verge Protection
 Install 1.8m chainwire fence before work begins and remove on completion. Reinstatement verge to condition found at commencement of works. The builder is responsible for reinstatement of all damage to land vegetation, services, paths, and roads, resulting from the works.

Gas Metering Equipment Prohibited Locations

Metering equipment must not be installed in the following locations unless specifically approved by **ActewAGL**:

- (a) a bedroom;
- (b) a lift shaft or lift motor room;
- (c) a room specifically intended for electrical switchgear;
- (d) a fire-isolated stairway or passage;
- (e) a fire hydrant duct or hose reel cabinet;
- (f) sprinkler or hydrant pump room;
- (g) near a source of ignition;
- (h) in a position that would obstruct egress from a building;
- (i) in a position where the meter would be subject to physical damage unless adequately protected;
- (j) in an area where excessive temperatures or sudden excessive changes in temperature may occur;
- (k) in an area of excessive vibration;
- (l) in the foundation area under a building;
- (m) in a cavity wall, unless installed in a ventilated enclosure which meets the requirements of **ActewAGL**, and the cavity is sealed;
- (n) in a position where access for reading or maintenance is restricted;
- (o) in an unventilated position; or
- (p) on the ground, a floor which is frequently wetted or on a floor which contains material which may corrode the meter.

Gas Metering Equipment In High Rise Buildings

1 General

Where a gas **meter set** is located in a room or enclosure in a high rise building, the door of this room must not open directly onto a fire stair or fire corridor.

2 Meters in Plant Rooms

Gas **meter sets** may be located in plant rooms in which gas fired equipment is located. The enclosing walls and door must have a fire resistance rating of two (2) hours and ventilation must comply with AS 5601.

3 Secondary Meter Set Enclosures

Where a Secondary **meter set** is being installed, the following must apply:

- (a) if the **meter set** is located inside the building, then the **meter set** must be enclosed in a two (2) hour fire rated enclosure;
- (b) if the **meter set** is located outside the building, then the **meter set** must be suitably protected against impact;
- (c) the **meter set** enclosure must be ventilated according to AS 5601;
- (d) if ventilation is by mechanical means, it must be limited to the gas **meter set** enclosure only, and it must not vent to any other area of the building;
- (e) where the **meter set** enclosure venting duct passes through a wall, it must be fitted with a fire damper;
- (f) a gas detector must be installed inside an internal secondary **meter set** enclosure, and be monitored at an approved central location; and
- (g) if the internal enclosure is designed to accommodate workmen, then the enclosure must be fitted with a fire sprinkler.

Gas Metering Equipment Meter Set Enclosures

When specified by **ActewAGL** an enclosure will be installed to prevent unauthorised access or damage to the meter/regulator set. The schematic drawing of such an enclosure is shown in Fig .3. No other equipment, such as water meters, pumps, compressors, fire hydrants etc must be placed within this compound unless authorised to do so in writing from **ActewAGL**.

Such housing or protection must:

- (a) have enough clearance to allow changing and servicing of the **meter set**, and
- (b) be ventilated according to the code requirements of AS 5601 Gas Installations.

1 Installation in an Open Enclosure

Meter sets (Copper and Steel) and Regulator Sets with a capacity greater than 75m³/h must comply with the following requirements:

- (c) the location of a **meter set** / regulator set must be approved by **ActewAGL** at the building/site design stage;
- (d) the security compound surrounding the **meter set** / **meter kit** must be as per Fig. 3 and locked with an **ActewAGL** supplied padlock;
- (e) the security compound must have two entry/exit doors located at opposite sides of the runs;
- (f) ventilation of a walled enclosure must comply with AS/NZS 2430.3.1;
- (g) within hazardous areas the boundaries must be greater than the **meter set** enclosure;
- (h) electrical equipment installed on metering equipment must comply with AS/NZS 2381.1 Electrical equipment for explosive atmospheres and AS/NZS 3000 Electrical installations;
- (i) **meter sets** / regulator kit must be installed with adequate clearance for maintenance work to be performed and comply with Fig. 3;
- (j) the compound floor of the **meter set** / regulator set must be constructed of concrete and be level; and

Figure 1

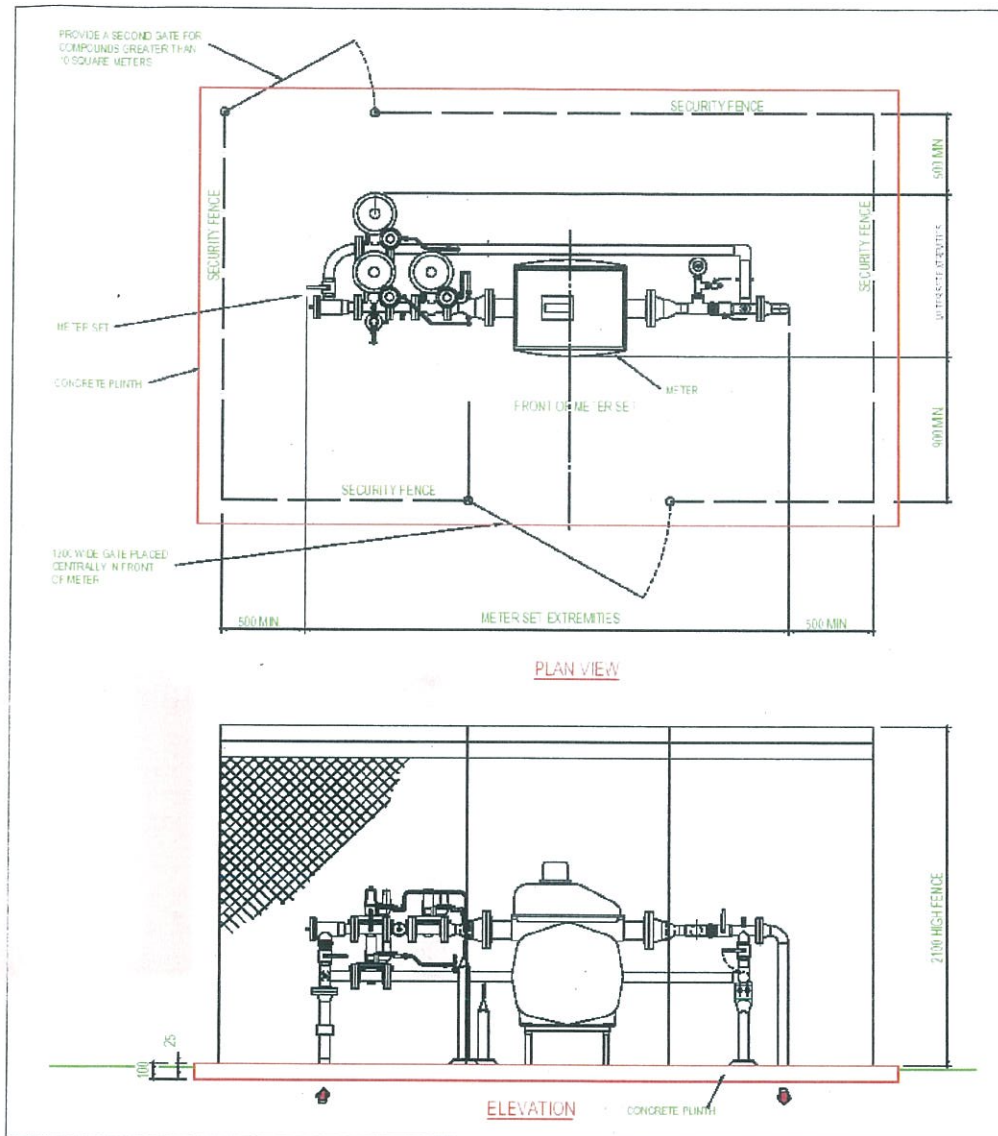
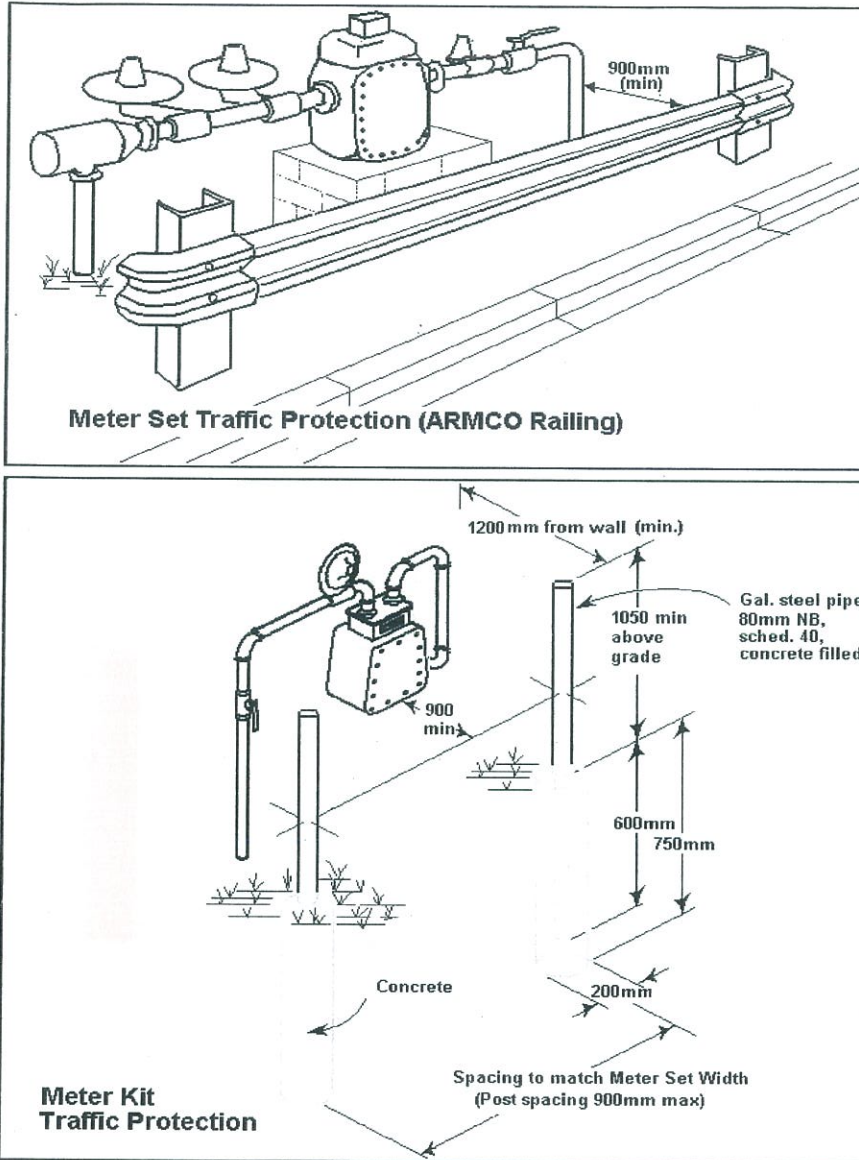

Figure 2



For further information please phone Steve Donnelly – Jemena 6203 0640

- (k) appropriate permanent safety barriers (e.g. Armco railing) must be installed between a gas/regulator set and adjacent vehicular traffic path. (see fig 2)

2 Installation in an enclosed area

Meter sets (Copper and Steel) and Regulator Sets with a capacity greater than 75m³/h must comply with the following requirements:

- (l) a room where a **meter set** / regulator set is installed must be situated by an external wall at ground level of the building with adequate ventilation for engulfment protection, unless specifically approved by **ActewAGL**.
- (m) the enclosure's walls and door must have a fire resistant rating of two hours;
- (n) the enclosure's ventilation must comply with AS 5601;
- (o) ventilation by mechanical means must only service the **meter set** / regulator set enclosure only and not vent any other area of the building;
- (p) any **meter set** / regulator set ventilation duct that passes through a wall must be fitted with a fire damper;
- (q) the enclosure must be fitted with a gas detector and that gas detector must be monitored at all times;
- (r) instrumentation and electrical equipment installed within an enclosure must comply with *AS/NZS 2381.1 Electrical Equipment for Explosive Atmospheres* and *AS/NZS 3000 Electrical installations*;
- (s) installation in confined space should be avoided; and
- (t) a **meter set** / regulator set must not be installed in a room containing an unsealed grease trap.

Robertson, Nathan

From: BAsubmission_watersewer@actewagl.com.au
Sent: Monday, 28 July 2014 12:37 PM
To: EPD, Customer Services
Subject: ActewAGL Application Decision. Application - 142863. Kingston - 13/49
Attachments: Conditional Approval142863.pdf; SITE-201425930-DEMOLITION PLAN-01.pdf; Demolition check list .pdf; Demolition-checklist-water-sewer.pdf

ACTEWAGL - WATER DIVISION

Approval ID : 142863, Kingston 13 /49

Your application has been assessed by ActewAGL against ACTEW water and sewerage network access and asset protection requirements.

Please find attached an ActewAGL DECISION STATEMENT together with your stamped plans.

A failure to comply with decision statement conditions will invalidate the approval and will expose the land-holder to prosecution under the Utilities Act 2000.

Non-compliant submissions must be rectified and resubmitted to ActewAGL for approval prior to construction commencing. A decision to proceed with construction using unapproved drawings will expose the land-holder to prosecution under the Utilities Act 2000.

Please note: Separate decision statements are required from other utilities (eg: electricity, gas, stormwater and communications)

Future applications

ActewAGL has introduced an online planning application process for obtaining utility clearances prior to submitting a development application or seeking building approval.

This revised application process consists of an electronic form available [here](#). By using the online form applicants will no longer need to complete the respective Water/Sewerage and Electricity/Gas application forms.

When an application is submitted it will be assessed against the water, sewerage, electricity and gas networks.

ActewAGL requests that organisations register their details if they regularly submit applications. Registration will reduce the time it takes to lodge an application. To register, send a return email including the organisation's name, a contact name, phone number and email address.

Regards

Eddie Gonzalez

Building Approvals and Network Protection
ActewAGL Water Division

Telephone 02 6248 3555 then press 2 for Water

Facsimile 02 6242 1459

Email devapp@ActewAGL.com.au

Please consider our environment before printing this email.

PLEASE NOTE This email and any attachments may be confidential. If received in error, please delete all copies and advise the sender. The reproduction or dissemination of this email or its attachments is prohibited without the consent of the sender.

WARNING RE VIRUSES: Our computer systems sweep outgoing email to guard against viruses, but no warranty is given that this email or its attachments are virus free. Before opening or using attachments, please check for viruses. Our liability is limited to the re-supply of any affected attachments.

Any views expressed in this message are those of the individual sender, except where the sender expressly, and with authority, states them to be the views of the organisation.

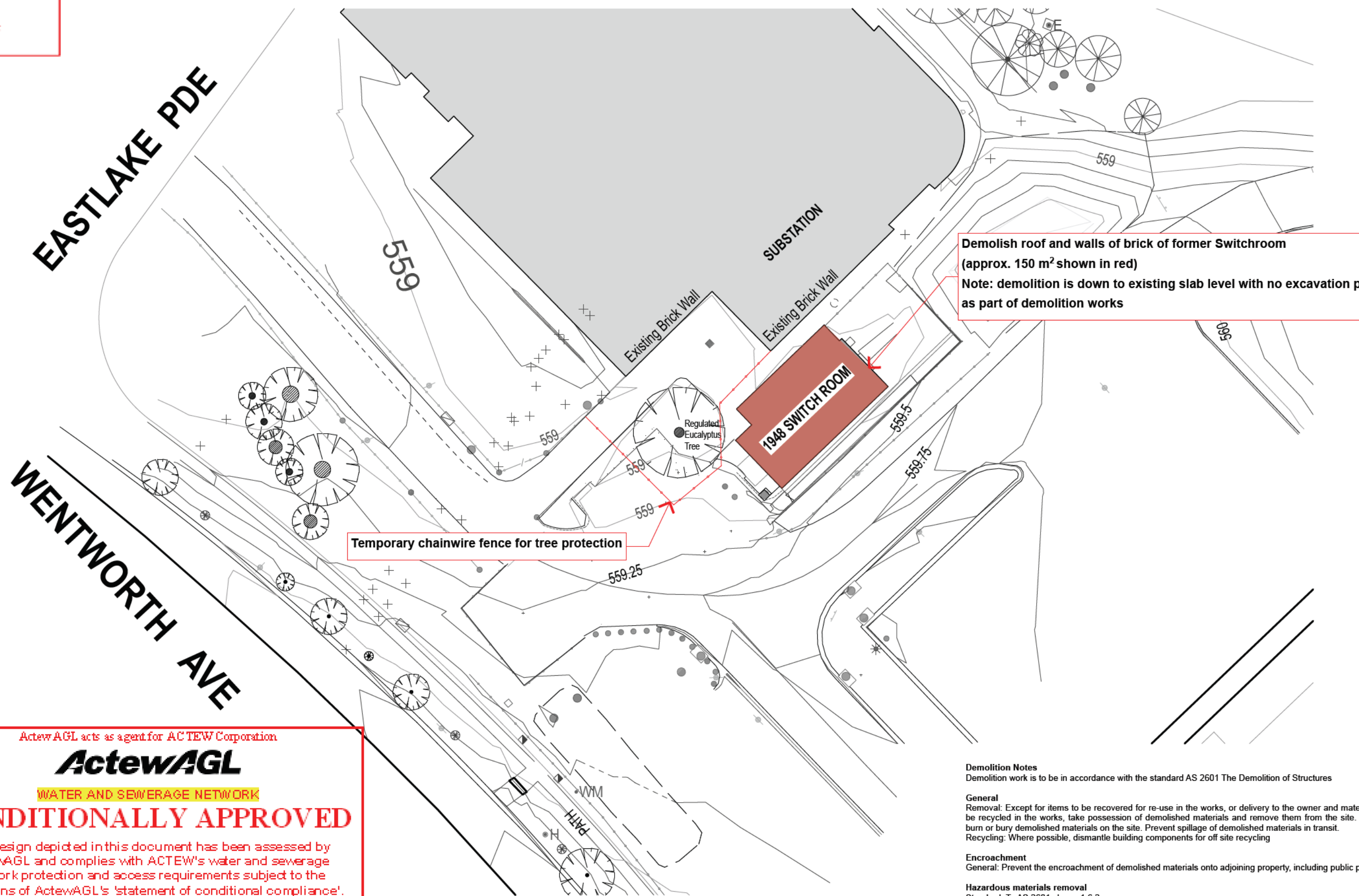

Demolish roof and walls of brick of former Switchroom (approx. 150 m² shown in red)
 Note: demolition is down to existing slab level with no excavation proposed as part of demolition works

Temporary chainwire fence for tree protection

ActewAGL acts as agent for ACTEW Corporation
ActewAGL
 WATER AND SEWERAGE NETWORK
CONDITIONALLY APPROVED
 The design depicted in this document has been assessed by ActewAGL and complies with ACTEW's water and sewerage network protection and access requirements subject to the conditions of ActewAGL's 'Statement of conditional compliance'.
 Signed **Eddie Gonzalez** Date **28 Jul 2014**
 Contact phone: 6248 3555 (then select 2)

Demolition Notes
 Demolition work is to be in accordance with the standard AS 2601 The Demolition of Structures

General
 Removal: Except for items to be recovered for re-use in the works, or delivery to the owner and materials to be recycled in the works, take possession of demolished materials and remove them from the site. Do not burn or bury demolished materials on the site. Prevent spillage of demolished materials in transit.
 Recycling: Where possible, dismantle building components for off site recycling

Encroachment
 General: Prevent the encroachment of demolished materials onto adjoining property, including public places.

Hazardous materials removal
 Standard: To AS 2601 clause 1.6.2.

Landscape Management & Verge Protection
 Install 1.8m chainwire fence before work begins and remove on completion. Reinstatement of condition found at commencement of works. The builder is responsible for reinstatement of all damage to land vegetation, services, paths, and roads, resulting from the works.

Sewer connection

ActewAGL's requirements for demolition work which could potentially damage ACTEW assets or result in discharge of stormwater, or other unapproved wastes (other than domestic sewage) to the ACTEW sewerage network.

The property owner (or their design or construction agent) is responsible for the following.

1. Where an ACTEW sewer main traverses a property or an ACTEW sewer main is outside the property boundary (and proposed demolition works may impact on the sewer main's pipe-protection-envelope), accurate sewer network survey plans must be obtained from ActewAGL or from a registered surveyor. Sewer asset locations need to be shown on relevant demolition plans including manhole, boundary riser and tie location with off-set dimensions from site boundaries.
2. Recording the condition of manhole covers. ActewAGL can be contacted on 13 11 93 to repair damaged components. A failure to identify any faults before demolition commences may result in the property owner (or their contractors) being held responsible to pay for the repair caused by a failure to adequately protect ACTEW's assets during the demolition or building construction works.
3. Engaging a licenced drainer to disconnect the internal sanitary drains before any demolition works commence. The discharge of debris, stormwater or other unapproved liquid wastes (other than domestic sewage into the sewerage networks) is an offence under the *Utilities Act 2000*.
4. Identifying, flagging, barricading and protecting the sanitary drainage 'riser' (if installed) and manholes from demolition operations.
5. Where further construction works is planned, sanitary drains are to be temporarily sealed by capping no closer than 3 metres from the ACTEW tie. Excavation and capping is to be undertaken by licensed drainers at the customer's expense. The capping point is to be staked behind the cap and identified at ground level. Please note the subsequent building contractor will be required to make a new sanitary drainage connection at the designated tie (not at the temporary cap). This may require the removal of old jump-ups in the customer's sanitary drains. When the tie is exposed it is recommended to ask ActewAGL to inspect the branch-line to ensure it is in good condition.
6. Where further construction work is not proposed to commence within 12 months from the date demolition commences, permanent disconnection may be required. Please consult ActewAGL at this time for a definitive answer.

For more information contact:

ActewAGL Water division technical enquiry line

Phone: 6248 3555 (press '2' for Water)

Fax: 6242 1459

Or visit the customer service counter during business hours
12 Hoskins Street, Mitchell.

Water supply

ActewAGL requirements for demolition works which could potentially damage ACTEW assets or result in contamination of the potable water supply.

The property owner (or their design or construction agent) is responsible for the following.

1. Where an ACTEW water main traverses a property (and where an ACTEW water main is outside the property boundary but proposed demolition works may impact on the water main's pipe-protection-envelope), accurate water network survey plans must be obtained from ActewAGL or from a registered surveyor. Water asset locations need to be shown (including mains, valves and hydrants) on relevant demolition plans (with off-set dimensions to site boundaries).
2. Identifying the location of the ACTEW isolation valve and water meter on the site plan (with off-set dimensions from site boundaries).
3. Recording the condition of the water connection pipe, isolation valve, water meter, verge hydrants and verge network valves. Please contact ActewAGL on 13 11 93 to repair damaged components. Failure to identify any faults before demolition works commence may result in the property owner (or their contractors) being held responsible to pay for the repair caused by a failure to adequately protect those assets during the demolition or building construction.
4. Engaging a licenced plumber to disconnect the internal plumbing service at the water meter before any demolition commences. The discharge of debris, stormwater or other unapproved liquid wastes (other than domestic sewage into the sewerage networks) is an offence under the *Utilities Act 2000*.
5. Where further construction works are planned, install a temporary hose cock adjacent to the meter. Retain the meter, meter box and hose cock for the duration of any building works. Identify, flag, barricade and protect the meter assembly from demolition operations and accidental damage. To avoid accidental wastage, turn off the isolation valve until required.
6. Where further construction works is not proposed to commence within 12 months from the date demolition commences, permanent disconnection and removal of the meter may be required. Please consult ActewAGL at this time for a definitive answer.
7. Flagging and protecting network isolation valves and hydrants (on the verge) from demolition operations and accidental damage.
8. Advising ActewAGL when demolition is complete. ActewAGL may take the opportunity to install a new isolation valve and meter assembly to the current ACTEW standard.

For more information contact:

ActewAGL Water division technical enquiry line

Phone: 6248 3555 (press '2' for Water)

Fax: 6242 1459

Or visit the customer service counter during business hours

12 Hoskins Street, Mitchell.

Sewer connection

ActewAGL's requirements for demolition work which could potentially damage ACTEW assets or result in discharge of stormwater, or other unapproved wastes (other than domestic sewage) to the ACTEW sewerage network.

The property owner (or their design or construction agent) is responsible for the following.

1. Where an ACTEW sewer main traverses a property or an ACTEW sewer main is outside the property boundary (and proposed demolition works may impact on the sewer main's pipe-protection-envelope), accurate sewer network survey plans must be obtained from ActewAGL or from a registered surveyor. Sewer asset locations need to be shown on relevant demolition plans including manhole, boundary riser and tie location with off-set dimensions from site boundaries.
2. Recording the condition of manhole covers. ActewAGL can be contacted on 13 11 93 to repair damaged components. A failure to identify any faults before demolition commences may result in the property owner (or their contractors) being held responsible to pay for the repair caused by a failure to adequately protect ACTEW's assets during the demolition or building construction works.
3. Engaging a licenced drainer to disconnect the internal sanitary drains before any demolition works commence. The discharge of debris, stormwater or other unapproved liquid wastes (other than domestic sewage into the sewerage networks) is an offence under the *Utilities Act 2000*.
4. Identifying, flagging, barricading and protecting the sanitary drainage 'riser' (if installed) and manholes from demolition operations.
5. Where further construction works is planned, sanitary drains are to be temporarily sealed by capping no closer than 3 metres from the ACTEW tie. Excavation and capping is to be undertaken by licensed drainers at the customer's expense. The capping point is to be staked behind the cap and identified at ground level. Please note the subsequent building contractor will be required to make a new sanitary drainage connection at the designated tie (not at the temporary cap). This may require the removal of old jump-ups in the customer's sanitary drains. When the tie is exposed it is recommended to ask ActewAGL to inspect the branch-line to ensure it is in good condition.
6. Where further construction work is not proposed to commence within 12 months from the date demolition commences, permanent disconnection may be required. Please consult ActewAGL at this time for a definitive answer.

For more information contact:

ActewAGL Water division technical enquiry line

Phone: 6248 3555 (press '2' for Water)

Fax: 6242 1459

Or visit the customer service counter during business hours
12 Hoskins Street, Mitchell.

Water supply

ActewAGL requirements for demolition works which could potentially damage ACTEW assets or result in contamination of the potable water supply.

The property owner (or their design or construction agent) is responsible for the following.

1. Where an ACTEW water main traverses a property (and where an ACTEW water main is outside the property boundary but proposed demolition works may impact on the water main's pipe-protection-envelope), accurate water network survey plans must be obtained from ActewAGL or from a registered surveyor. Water asset locations need to be shown (including mains, valves and hydrants) on relevant demolition plans (with off-set dimensions to site boundaries).
2. Identifying the location of the ACTEW isolation valve and water meter on the site plan (with off-set dimensions from site boundaries).
3. Recording the condition of the water connection pipe, isolation valve, water meter, verge hydrants and verge network valves. Please contact ActewAGL on 13 11 93 to repair damaged components. Failure to identify any faults before demolition works commence may result in the property owner (or their contractors) being held responsible to pay for the repair caused by a failure to adequately protect those assets during the demolition or building construction.
4. Engaging a licenced plumber to disconnect the internal plumbing service at the water meter before any demolition commences. The discharge of debris, stormwater or other unapproved liquid wastes (other than domestic sewage into the sewerage networks) is an offence under the *Utilities Act 2000*.
5. Where further construction works are planned, install a temporary hose cock adjacent to the meter. Retain the meter, meter box and hose cock for the duration of any building works. Identify, flag, barricade and protect the meter assembly from demolition operations and accidental damage. To avoid accidental wastage, turn off the isolation valve until required.
6. Where further construction works is not proposed to commence within 12 months from the date demolition commences, permanent disconnection and removal of the meter may be required. Please consult ActewAGL at this time for a definitive answer.
7. Flagging and protecting network isolation valves and hydrants (on the verge) from demolition operations and accidental damage.
8. Advising ActewAGL when demolition is complete. ActewAGL may take the opportunity to install a new isolation valve and meter assembly to the current ACTEW standard.

For more information contact:

ActewAGL Water division technical enquiry line

Phone: 6248 3555 (press '2' for Water)

Fax: 6242 1459

Or visit the customer service counter during business hours

12 Hoskins Street, Mitchell.



STATEMENT OF CONDITIONAL COMPLIANCE

Application No: 142863 **Suburb:** Kingston **Block/Section** 13 / 49

Applcn Type: Non residential/Demolition Inclusions : with Shed

Attached Plans

SITE-201425930-DEMOLITION PLAN-01.pdf

Conditions

ACTEW Corporation assets shall be protected for the duration of the construction works from short term load shedding from construction machinery or vibration and groundwater ingress or infiltration. Any damage to ACTEW assets resulting from the construction works shall be repaired by ACTEW Water at the contractors expense. Access to ACTEW assets including sewer structures, manholes, hydrants and valves is to be maintained for the duration of the construction works.

Protection of water and sewer networks to be in accordance with the attached checklist

Please Note:

- ❖ Separate applications are required for ActewAGL electricity and gas networks.
- ❖ Any failure to accurately show existing or proposed structures may result in damage and costs for which the property owner will be liable. Damage to network assets must be reported to ActewAGL.
- ❖ Utility conditions may also apply to minor structures and landscaping works that may not have been depicted in this document. Consultation with ActewAGL's Water Division is advised if such structures and landscaping are planned.
- ❖ ActewAGL recommend setbacks provided for equipment access to water or sewerage network assets are kept free of obstruction by the property owner.
- ❖ Construction of works without the approval of ActewAGL may result in connection to ACTEW's water and sewerage networks being denied and /or action being taken to require the property owner to remove non-compliant services (e.g. sanitary drains) or structures.

Please refer to Info Sheets

Demolition check list .pdf

WARNING

Failure to comply with these conditions is likely to result in interference with an ACTEW Corporation water or sewer asset. Sections 123 to 125 of the Utilities Act 2000 apply, which indicates a person who interferes with a utility asset may be subject to prosecution. The current maximum penalty is a fine of \$50,000, imprisonment for six months or both. In addition the land-holder can be ordered at their expense to stop the interference, which may involve removal of the building work or that part of the building work that is causing, or is likely to cause interference.

Comments:

Signed

Eddie Gonzalez

Date

28 Jul 2014

For further information please phone ActewAGL 6248 3555 (then 2).

Robertson, Nathan

From: basubmission_electricity@actewagl.com.au
Sent: Friday, 8 August 2014 12:33 PM
To: EPD, Customer Services
Subject: ActewAGL Application Decision. Application - 142826. Kingston - 13/49
Attachments: Conditional Approval Electricity142826.pdf; SITE-201425930-DEMOLITION PLAN-01.pdf; 3832_018.pdf

ACTEWAGL - ELECTRICITY NETWORKS DIVISION

Approval ID : 142826, Kingston 13 /49

Please note that your application has been assessed for compliance with ActewAGL's Electricity Network and conditionally complies with our Electricity Networks requirements.

Please find attached, your stamped plans together with a conditional statement of compliance.

Separate compliance statements may be required from other entities.

Regards

Denise Thurtell
[ActewAGL Electricity Networks Division](#)

Telephone 02 6293 5770
Facsimile 02 6293 5762
Email devapp@ActewAGL.com.au
GPO Box 366 Canberra ACT 2601
www.ActewAGL.com.au

Please consider our environment before printing this email.

PLEASE NOTE This email and any attachments may be confidential. If received in error, please delete all copies and advise the sender. The reproduction or dissemination of this email or its attachments is prohibited without the consent of the sender.

WARNING RE VIRUSES: Our computer systems sweep outgoing email to guard against viruses, but no warranty is given that this email or its attachments are virus free. Before opening or using attachments, please check for viruses. Our liability is limited to the re-supply of any affected attachments.

Any views expressed in this message are those of the individual sender, except where the sender expressly, and with authority, states them to be the views of the organisation.

EASTLAKE PDE

WENTWORTH AVE

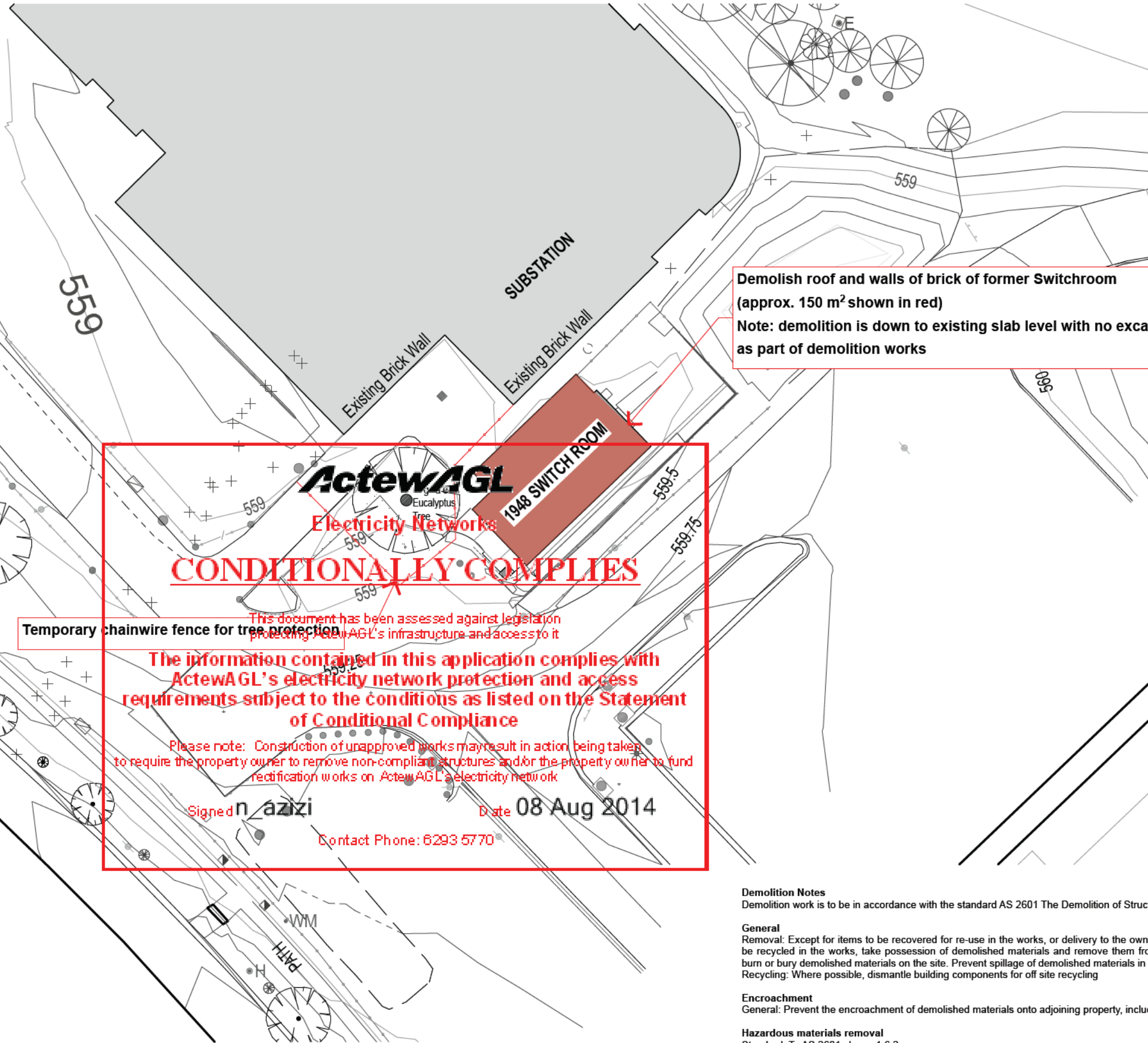

Demolish roof and walls of brick of former Switchroom (approx. 150 m² shown in red)
 Note: demolition is down to existing slab level with no excavation proposed as part of demolition works

ActewAGL
 Electricity Networks
CONDITIONALLY COMPLIES

This document has been assessed against legislation protecting ActewAGL's infrastructure and access to it

The information contained in this application complies with ActewAGL's electricity network protection and access requirements subject to the conditions as listed on the Statement of Conditional Compliance

Please note: Construction of unapproved works may result in action being taken to require the property owner to remove non-compliant structures and/or the property owner to fund rectification works on ActewAGL's electricity network

Signed **n. azizi** Date **08 Aug 2014**
 Contact Phone: 6293 5770

Temporary chainwire fence for tree protection

Demolition Notes
 Demolition work is to be in accordance with the standard AS 2601 The Demolition of Structures

General
 Removal: Except for items to be recovered for re-use in the works, or delivery to the owner and materials to be recycled in the works, take possession of demolished materials and remove them from the site. Do not burn or bury demolished materials on the site. Prevent spillage of demolished materials in transit.
 Recycling: Where possible, dismantle building components for off site recycling

Encroachment
 General: Prevent the encroachment of demolished materials onto adjoining property, including public places.

Hazardous materials removal
 Standard: To AS 2601 clause 1.6.2.

Landscape Management & Verge Protection
 Install 1.8m chainwire fence before work begins and remove on completion. Reinstatement of verge to condition found at commencement of works. The builder is responsible for reinstatement of all damage to land vegetation, services, paths, and roads, resulting from the works.



Electricity Networks

STATEMENT OF

CONDITIONAL COMPLIANCE

Application No: 142826 **Suburb:** Kingston

Block/Section 13 / 49

Applcn Type: Non residential/Demolition Inclusions : with Substation

Attached Plans

SITE-201425930-DEMOLITION PLAN-01.pdf

This application is approved subject to compliance with the following conditions:

Conditions

Development is to comply with minimum separation requirements to underground assets. Ref ActewAGL Drawing 3832-018

Proponent is required to submit the Request for "Preliminary Network Advice" form to enworks@actewagl.com.au (available on ActewAGL website) prior to commencement of any development activity to negotiate the connection of new and/or relocation of existing electricity assets.

Please Note

- WARNING ActewAGL underground cables may be in or adjacent to this block. It is your responsibility to ascertain the location of such assets.
- Development and Building Applications will need to include any proposed ActewAGL works
- If ActewAGL approval conditions are not met, a breach of the law may result.
- Separate applications are required for water & sewerage, and communication network services.
- Construction of unapproved works may result in action being taken to require the property owner to remove non-compliant structures and/or the property owner to fund rectification works on ActewAGL's electricity network.
- Any attached reticulation or servicing plan is preliminary only. Contact ActewAGL for final plans prior to the commencement of any construction activity.
- A failure of this application to show accurately located electricity assets may result in damage and costs for which the proponent will be liable. Damage to network assets must be reported to ActewAGL.

Comments:

Signed Nadeem Azizi

Date 08 Aug 2014

application number

142826

Sheet
2 of 2

MINIMUM SEPARATION REQUIREMENTS					RECOMMENDED BURIAL DEPTHS FOR UNDERGROUND LINES (FROM SURFACE TO THE TOP OF THE CABLE)				
FROM ANY PART OF	TO NEAREST PART OF:	SEPARATION (m) SEPARATE EARTHING	SEPARATION (m) CMEN & COMBINED EARTHING SITUATIONS	TYPE OF UNDERGROUND LINE	DIRECT BURIED WITH NO ADDITIONAL MECHANICAL PROTECTION (NOTE 5) NOMINAL (MINIMUM) (mm)	DIRECT BURIED AND COVERED WITH A MECHANICAL COVER NOMINAL (MINIMUM) (mm)	ENCLOSED IN A HEAVY DUTY PIPE OR CONDUIT (NOTE 4) NOMINAL (MINIMUM) (mm)		
PADMOUNT SUBSTATION	-BUILDING	1.5 (NOTE 3)	1.5 (NOTE 3)	LV SERVICE LINE	750 (600)	600 (450)	550 (450)		
	-PROPERTY BOUNDARY	1.5	1.5	LV MAINS	750 (600)	750 (600)	750 (600)		
	-GROUND OBJECTS	1.5	1.5	1kV <U≤ 22kV	850 (750)	850 (600)	750 (600)		
	-DRIVEWAYS & ROADS	1.5	1.5	22kV <U≤ 132kV	NOT PERMITTED	1000 (1000)	1000 (1000)		
	-COMMUNICATIONS CABLES, GAS & WATER PIPES, SEWER LINES	1.5 (NOTE 12)	1.5 (NOTE 12)	BURIAL NOTES: 1. FIGURES IN BRACKETS INDICATE MINIMUM REQUIREMENT 2. ALL CABLES INSTALLED UNDER ROADWAYS SHALL HAVE A MINIMUM BURIAL DEPTH OF 750mm 3. MAXIMUM TRENCH DEPTH FOR INSTALLATION OF CABLES IS 1.5 METRES 4. HEAVY DUTY CONDUITS TO AS2053.2 AND CLASS 12 PRESSURE PIPES TO AS1477 MAY BE CONSIDERED SUITABLE FOR THE HEAVY DUTY CATEGORY. (CORFLO TYPES ARE NOT ACCEPTABLE) 5. THIS CATEGORY ALSO INCLUDES CABLES INSTALLED IN CONDUITS THAT ARE NOT RATED AS HEAVY DUTY (FOR EXAMPLE CONDUITS INSTALLED BY UNDERGROUND BORING)					
	-DESIGNATED HAZARDS	NOTE 5	NOTE 5						
	-NON FIRE RATED PARTS OF BUILDINGS	3 (NOTE 3)	3 (NOTE 3)						
	-BUILDINGS & STRUCTURES	1.2 (NOTE 8)	1.2 (NOTE 8)						
	-PROPERTY BOUNDARY	1.2 (NOTE 8)	1.2 (NOTE 8)						
	MINI PILLAR	-ROADS	1.2					1.2	
	-DRIVEWAYS	1.5	1.5						
	-SHRUBS AND SMALL TREES	1.2 (NOTES 8 & 10)	1.2 (NOTES 8 & 10)						
HV CABLES (1kV <U≤ 22kV)	-WATER PIPES	0.5 (H) (NOTE 12)	0.5 (H) (NOTE 12)						
	-SEWER PIPE LINES & STORMWATER PIPE LINES	0.6 (H), (NOTES 1 & 12)	0.6 (H), (NOTES 1 & 12)						
	-COMMUNICATIONS CABLES	0.3	0.3						
	-GAS PIPES	0.3	0.3						
	-HV CABLES (22kV <U≤ 132kV)	0.75 (NOTE 11)	0.75 (NOTE 11)						
	-EDGE OF INGROUND SWIMMING POOLS OR SPAS	3.5 (NOTE 9)	3.5 (NOTE 9)						
	-HV CABLES (1kV <U≤ 22kV)	0.2 (MIN)	0.2 (MIN)						
LV CABLES (<= 1kV) SERVICE MAINS CABLE PITS	-WATER PIPES	0.5 (H)	0.5 (H)						
	-SEWER PIPE LINES & STORMWATER PIPE LINES	0.6 (H), (NOTES 1 & 12)	0.6 (H), (NOTES 1 & 12)						
	-COMMUNICATIONS CABLES	0.15	0.15						
	-GAS PIPES	0.15	0.15						
	-EDGE OF INGROUND SWIMMING POOLS OR SPAS	3.5 (NOTE 9)	3.5 (NOTE 9)						
	-HV CABLES (1kV <U≤ 22kV)	0.09	0.09						
HV EARTHING ELECTRODE(S) HV EARTH CONDUCTORS (NOTE 6)	HV EARTH RESISTANCE								
		30Ω	10Ω	5Ω	3Ω				
	-IN GROUND SWIMMING POOLS, SPAS & CHILDRENS METAL PLAYGROUND EQUIPMENT (NOTE 4)	30	20	15	12	4 (NOTE 4)			
	-TELECOMMUNICATIONS PITS, PILLARS, JOINTS, EXCHANGES & PABX EQUIPMENT	15	10	8	6	4			
	-UG UNINSULATED METALWORK AND METAL PIPES	4	3	2	2	2			
	-METAL FENCING OR METAL CLAD BUILDINGS	4	3	2	2	2			
	-LV EARTHING ELECTRODE(S)	4	3	2	2	0			
	-BARE UG LV EARTH CONDUCTORS	4	3	2	2	0			
	BARE UG LV EARTH CONDUCTORS (INCL. STEEL & CONCRETE POLES) BARE UG LV EARTH CONDUCTORS (NOTE 7)	-UG UNINSULATED METALWORK AND METAL PIPES	2			2			
		-CONCRETE REINFORCING BONDED TO HV EARTH	SEE HV ELECTRODE			N/A			
-INGROUND SWIMMING POOLS, SPAS & CHILDRENS METAL PLAYGROUND EQUIPMENT		4			4				
-COMMUNICATIONS EARTH STAKE		0.5			4				

SEPARATION NOTES:

- CROSSOVER CLEARANCES: SEWER & STORMWATER PIPE LINES - LV CABLES 150mm
SEWER & STORMWATER PIPE LINES - HV CABLES 300mm
- (H) - HORIZONTAL CLEARANCE REQUIRED
- ANY PART OF A BUILDING WITHIN 3 METRES OF THE SUBSTATION SHALL HAVE A ONE HOUR FIRE RATING
- SUBSTATIONS WITH SEPARATE EARTHING SYSTEMS ARE NOT PERMITTED IN SPECIAL LOCATIONS. LOCATIONS WITHIN 100m OF SCHOOL GROUNDS, CHILDREN'S PLAYGROUND, SWIMMING POOL OR IN A PUBLIC THOROUGHFARE ARE GENERALLY CLASSIFIED AS SPECIAL LOCATIONS.
- SUBSTATIONS ARE NOT PERMITTED IN HAZARDOUS AREAS, REFER AS2381 OR HB13
- INCLUDES GRADING RINGS AND EXCLUDES DEEP ELECTRODES
- BARE UG LV EARTH CONDUCTORS ALSO INCLUDES EARTHS ASSOCIATED WITH MINIPILLARS AND ANY OTHER LV EQUIPMENT THAT IS EARTHED
- THIS FIGURE CAN BE REDUCED ON ONE SIDE ONLY (NOT THE FRONT) TO 300mm
- THIS FIGURE CAN BE REDUCED TO 500mm PROVIDED THE CABLE IS INSTALLED IN A HEAVY DUTY PLASTIC NON CONDUCTIVE PIPE AND ANY JOINS IN THE PIPE ARE MADE WATERPROOF WITH A NON CONDUCTIVE ADHESIVE
- THIS FIGURE SHOULD BE INCREASED FOR TREES THAT WILL GROW TO A HEIGHT IN EXCESS OF THREE METRES AT MATURITY
- NO STRUCTURES OR SERVICES ARE PERMITTED WITHIN 750mm OF THE VERTICAL PROJECTION OF ANY 132KV CABLES
- REFER TO THE PROXIMITY GUIDELINES (DM#468024) AS THERE ARE ADDITIONAL REQUIREMENTS FOR WATER, SEWER AND ELECTRICITY ASSETS WITHIN LEASED LAND.
- SUBSTATION EARTHING DESIGN SHALL COMPLY WITH THE FOLLOWING STANDARDS
 - ENA EG-0 (2010): POWER SYSTEM EARTHING
 - ENA EG-1 (2006): SUBSTATION EARTHING GUIDE
 - AS7000: OVERHEAD LINE DESIGN (FORMERLY ENA C(b)1)

C A D D	K	MINIPILLAR - DRIVEWAY CHANGED TO TAMS DS4-03	08-10-10	AC	BB		Drawn	GA
	J	NOTE 12 ADDED	24-5-10	GA	GA		Designed	gcsmith
	H	NON FIRE RATED PARTS ADDED, NOTE 8 REVISED	26-08-08	AC	GA		Checked	
	M	NOTE 4 AMENDED	06-02-14	CD	BS		Branch Engineer	G ASTBURY
	L	HV-HV & HV-LV SEPARATIONS ADDED, NOTES AMENDED	11.04.13	EA	BS		Branch Manager	D. Howe
No	REVISION		DATE	OKD	AUTH			

SEPARATION AND COVER REQUIREMENTS FOR CABLES AND PLANT

Scale:	Date:	Sheet No:
NA		
File:	Tender No:	
A3	3832-018	Rev M

(advertisement for The Canberra Times)

Fax to: **The Canberra Times (Classifieds) Fax 6280 2119**
Account Name: ACT Planning and Land Authority
Account Number: 1277730
Department's contact: Customer Service Centre 6207 1923
Publication Date: 28 July 2014
Size of Advertisement: Single Column
Classification: Development Applications
Order Number: KINGS49B13



ACT
Government
Environment and Planning

The Planning and Land Authority has received the following development applications:

Development Application 201425930CT: COMMERCIAL

Location: Block: **13** Section: **49** Suburb: **KINGSTON**

11 WENTWORTH AVENUE

Proposed demolition of the existing switchroom down to existing slab level.

Full details of the applications are available for public inspection at **www.environment.act.gov.au** (Comment on a DA) or at the ESDD Customer Service Centre, 16 Challis Street, DICKSON between 8:30am and 4:30pm Monday to Friday.

Written representations **MUST** be received by **close of business 18 August 2014** to be considered during the assessment of the application.

Representations can be submitted to esddcustomerservices@act.gov.au or posted to ESDD Representations – PO Box 365 Mitchell ACT 2911.

Copies of representations will be provided to the applicant and placed on the public register unless exclusion has been granted.

CANBERRA TIMES ADVERTISEMENT

DATE: 28-7-14



ACT
Government

Environment and
Sustainable Development

THE Planning and Land Authority has received the following development applications:

DA 201425918CT: COMMUNITY FACILITY - NEW BUILDING - LEASE VARIATION.

Location: Block: 6, 7 Section: 50

Suburb: MONASH

15 COCKCROFT AVENUE

Consolidation of part Block 6 and Block 7. Proposed construction of a single storey Community Activity Centre with associated landscaping and civil works, a new driveway and Signage. Please see application form for Lease Variation details.

DA 201425930CT: COMMERCIAL.

Location: Block: 13 Section: 49

Suburb: KINGSTON

11 WENTWORTH AVENUE

Proposed demolition of the existing switchroom down to existing slab level.

Written representations **MUST** be received by **COB 18 August 2014** to be considered.

Full DA details are at

www.environment.act.gov.au or at the ESDD Customer Service Centre, 16 Challis Street, DICKSON from 8:30am-4:30pm weekdays.

Representations can be submitted by post to ESDD Representations, PO Box 365, Mitchell ACT 2911 or emailed to esddcustomerservices@act.gov.au

Representations will be provided to the applicant and made available on the public register unless exclusion is granted.



24 July 2014

DAVID WHITNEY
GPO BOX 158
CANBERRA ACT 2601

Dear Property Owner

Suburb: KINGSTON Block: 13 Section: 49
Development Application Number: 201425930

The *Planning and Development Act 2007* requires the above-mentioned development application recently lodged on your behalf to be publically notified. Letters have been sent to the owners of the properties that adjoin the proposed development, a sign placed on the property and an advertisement placed in the Canberra Times.

The notification period commences on **29 July 2014** and ends at the close of business on **18 August 2014**. A copy of any representations received as a result of this process will be forwarded to the applicant.

The prescribed period for making a decision on your application is 30 working days from the date of lodgement. However, if representations are received as a result of the public notification process the time frame for making a decision will be extended by an additional 15 working days.

If the time for deciding the application (the prescribed period) has ended and a decision has not been reached your application will be deemed refused. The Planning and Land Authority (the Authority) will not provide written advice of this decision. It is important to note that the Authority is still able to finalise its consideration of your application and make a decision after the expiration of the prescribed period.

The applicant will be advised when a decision on your application has been made and of any appeal rights that may be applicable.

If you would like any further information in relation to this letter please contact the Customer Service Centre on (02) 6207 1923 or email esddcustomerservices@act.gov.au

Customer Service Centre

Environment and Planning Directorate

Customer Service Centre
16 Challis Street, Dickson
PO Box 365, Mitchell, ACT 2911 • Telephone: (02) 6207 1923 • Email: esddcustomerservices@act.gov.au
Website: www.actpla.act.gov.au



24 July 2014

PHILIP PHILIP LEESON ARCHITECTS
4/9 MCKAY ST
Turner ACT 2612

Dear Applicant

Suburb: KINGSTON Block: 13 Section: 49
Development Application Number: 201425930

The *Planning and Development Act 2007* requires the above-mentioned development application to be publically notified. This process includes a written notice being sent to adjoining lessees, a sign placed on the property and a notice in the Canberra Times.

The public notification period for your application will commence on **29 July 2014** and end at the close of business on **18 August 2014**. Representations must be made within the notification period to be considered during the assessment of the application. A copy of any representations received as a result of this process will be forwarded to you.

Please note, the sign will be removed from the property on 19 August 2014.

The prescribed period for making a decision on your application is 30 working days from the date of lodgement. However, if representations are received as a result of the public notification process the time frame for making a decision will be extended by an additional 15 working days.

If the time for deciding the application (the prescribed period) has ended and a decision has not been reached your application will be deemed refused. The Planning and Land Authority (the Authority) will not provide written advice of this decision. It is important to note that the Authority is still able to finalise its consideration of your application and make a decision after the expiration of the prescribed period.

You will be advised when a decision on your application has been made and of any appeal rights that may be applicable.

If you would like any further information in relation to this letter please contact the Customer Service Centre on (02) 6207 1923 or email esddcustomerservices@act.gov.au

Customer Service Centre

Environment and Planning Directorate

Customer Service Centre

16 Challis Street, Dickson

PO Box 365, Mitchell, ACT 2911 • Telephone: (02) 6207 1923 • Email esddcustomerservices@act.gov.au

Website: www.actpla.act.gov.au



ACT
Government
Environment and Planning

24 July 2014

NOTE: If you are not the owner of this property please forward this letter to your landlord or managing agent

THE RESIDENT
1/7 EASTLAKE PARADE
KINGSTON ACT 2604

Dear Property Owner

The following Development Application in relation to 11 WENTWORTH AVENUE has been lodged with the Planning and Land Authority for consideration.

Development Application 201425930:

COMMERCIAL. Proposed demolition of the existing switchroom down to existing slab level.

**Location: Block: 13 Section: 49 Suburb: KINGSTON
11 WENTWORTH AVENUE**

If you feel an application may impact on you in any way you may wish to submit a written representation clearly stating the reasons for your submission.

The application is available for public inspections between 8.30am and 4.30pm weekdays at:

**Environment and Planning Directorate
Customer Service Centre
Dame Pattie Menzies House
Ground Floor (right hand building)
16 Challis Street, DICKSON ACT**

Please bring this letter with you for reference.

The application can also be viewed on the Authority website

<http://www.act.gov.au/developmentapplications>

Representations **must** be made within the specified public notification period to be considered during the assessment of the application. Representations received outside the notification period **will not** be considered.

Representations must be received by the Authority by close of business **18 August 2014**.

Representations can be submitted in the following ways:

Email:
esddcustomerservices@act.gov.au

Post:
Customer Service
Centre

By Hand:
Dame Pattie Menzies
House

Environment and Planning Directorate

Customer Service Centre

16 Challis Street, Dickson

PO Box 365, Mitchell, ACT 2911 • Telephone: (02) 6207 1923 • Email: esddcustomerservices@act.gov.au

Website: www.actpla.act.gov.au

PO Box 365
Mitchell ACT 2911

16 Challis Street,
DICKSON ACT

It is standard practice for the Authority to acknowledge, in writing, any representations received as a result of public notification within 3-4 business days of the submission being received. If you don't receive this acknowledgement please contact the Authority. If you make your representation within the prescribed notification period the issues raised in your submission will be taken into consideration during the assessment of the development application and you will be notified in writing once the decision has been made.

A copy of your representation will be forwarded to the development application applicant and placed on the public register unless exclusion has been granted.

You may request to have part or all of your representation excluded from the public register under Sections 411 or 412 of the *Planning and Development Act 2007*. The request for exclusion must be in writing and clearly identify what you are seeking to exclude and how the request satisfies the exclusion criteria. The Authority may approve or refuse to approve an exclusion application.

If your request for exclusion is approved the Authority will seek to protect the information from disclosure. However, the Authority can not guarantee that the information will not have to be disclosed pursuant to a legal obligation.

If you would like any further information in relation to this letter please contact the Dickson Customer Service Centre on (02) 6207 1923 or email esddcustomerservices@act.gov.au

Yours faithfully

Customer Services
Environment and Planning Directorate

Name,Address1,Address2,Address3,Address4

CLANCY (ACT) PTY LIMITED, DIMOR PTY LTD, MANTEENA PTY LTD, MEGALO ACCESS ARTS INC, PRO MUSICA INC, PROJECT COORDINATION (AUSTRALIA) PTY LTD,18 NATIONAL CIRCUIT BARTON ACT 2600,,

Philip Philip Leeson Architects,4/9 McKay St,Turner ACT 2612,

The Resident,61 GILES STREET,KINGSTON ACT 2604,

The Resident,17 EASTLAKE PARADE,KINGSTON ACT 2604,

The Resident,7 EASTLAKE PARADE,KINGSTON ACT,

artsACT,ArtsACT,Community Services Directorate,GPO Box 158, Canberra ACT 2601

[REDACTED] 477 KAMERUKA LANE,CANDELLO,NSW 2550

[REDACTED] 75 JERVOIS STREET,DEAKIN ACT 2600,

[REDACTED] UNIT 6,43 GILES STREET,KINGSTON ACT 2604

[REDACTED] 32/9 HOWITT STREET,KINGSTON,ACT 2604

[REDACTED] 16 SURFERS PARADE,THIRROUL,NSW 2515

[REDACTED] 2604,,

[REDACTED] 49 BURRENDONG STREET,DUFFY ACT 2611,

THE PROPRIETORS UNIT PLAN NO 666,U 11 LATHLAIN STREET,BELCONNEN 2615,2615

Supernova Nominees Pty Ltd,228 BROUGHAM PLACE,NORTH ADELAIDE,SA 5006

[REDACTED] PO BOX 4487,KINGSTON,2604

[REDACTED] 34 DILLON GROVE,GELN IRIS,VIC 3146

[REDACTED] 26A WENTWORTH CRT 43-51, GILES STREET,KINGSTON ACT 2604

[REDACTED] 86 BANKS STREET,YARRALUMLA ACT 2600,

[REDACTED] UNIT 17 WENTWORTH COURT,43 GILES STREET,KINGSTON ACT 2604

[REDACTED] UNIT 27,43 GILES STREET,KINGSTON ACT 2604

[REDACTED] UNIT 27,43 GILES STREET,KINGSTON ACT 2604

[REDACTED] 54 SHARWOOD CRESCENT,EVATT ACT 2617,

[REDACTED] 51 GILES STREET,KINGSTON ACT 2604,

[REDACTED] UNIT 41,20 WENTWORTH AVENUE,KINGSTON ACT 2604

[REDACTED] 7 HAYNES PLACE,STIRLING ACT 2611,

[REDACTED] 41 CURLEWIS CRESCENT,GARRAN ACT 2605,

[REDACTED] 62 JAEGER CIRCUIT,BRUCE ACT 2617,

[REDACTED] 4A/43-51, GILES STREET,KINGSTON ACT 2604

[REDACTED] 1/54 MACLEAY STREET,TURNER ACT 2612,

[REDACTED] UNIT 3 43 GILES STREET,KINGSTON 2604,

[REDACTED] 4 MACDONNELL STREET,YARRALUMLA ACT 2600,

[REDACTED] 7/41 GILES STREET,KINGSTON 2604,2604

[REDACTED] 11/1 GOLDMAN STREET,BRUCE ACT 2617,

[REDACTED] 4A/43-51, GILES STREET,KINGSTON ACT 2604

[REDACTED] 17 PERRY DRIVE,CHAPMAN ACT 2611,

[REDACTED] C/- PETER BLACKSHAW MANUKA, PO BOX 3788 MANUKA 2603,ACT,

[REDACTED] UNIT 3 43 GILES STREET,KINGSTON 2604,

[REDACTED] 9/43, GILES STREET,KINGSTON ACT 2604

[REDACTED] 15/43 51 GILES STREET KINGSTON 2604,ACT,

[REDACTED] 51 GILES STREET,KINGSTON ACT 2604,

[REDACTED] 10 CHAPMAN STREET,BRADDON ACT 2612,

[REDACTED] 17 FERDINAND STREET,CAMPBELL ACT 2612,

[REDACTED] 9 BEAVER STREET,EAST MALVERN,VIC 3145

[REDACTED] GPO BOX 1564,CITY,ACT 2601

[REDACTED] 22/43-51, GILES STREET,KINGSTON ACT 2604

[REDACTED] BOX 2209,ORANGE,NSW 2800

[REDACTED] 2 MORESBY STREET,RED HILL,ACT 2603

[REDACTED] 16 SURFERS PARADE,THIRROUL,NSW 2515

[REDACTED] 15A WENTWORTH COURT",43 GILES STREET,KINGSTON ACT 2604

[REDACTED] 27 ARTHUR CIRCLE,GRIFFITH ACT 2603,

[REDACTED] 14/43 51 GILES STREET KINGSTON 2604,ACT,

[REDACTED] 10/43-51, GILES STREET,KINGSTON ACT 2604

[REDACTED] MCKINLAY STREET,NARRABUNDAH ACT 2604,

[REDACTED] 17A,43 GILES STREET,KINGSTON ACT 2604

[REDACTED] 5 SORLIE PLACE,CHAPMAN ACT 2611,

[REDACTED] 10 CHAPMAN STREET,BRADDON ACT 2612,

[REDACTED] 28/43-51 GILES STREET,KINGSTON,ACT 2604

[REDACTED] FRANCIS STREET,MANLY,NSW 2095

[REDACTED] 17A,43 GILES STREET,KINGSTON ACT 2604

[REDACTED] 8 BLACKWOOD PLACE,JERRABOMBERRA,NSW 2619

[REDACTED] UNIT 19A WENTWORTH COURT", GILES STREET,KINGSTON ACT 2604

[REDACTED] GILES STREET,KINGSTON ACT 2604,

[REDACTED] P O BOX 5107,KINGSTON ACT 2604,

[REDACTED] 34/71 GILES STREET,KINGSTON ACT 2604,

[REDACTED] PO BOX 5044,KINGSTON ACT 2604,

[REDACTED] 28/71 GILES STREET,KINGSTON ACT 2604,

[REDACTED],90 GURRANG AVENUE,NGUNNAWAL ACT 2913,

[REDACTED] GPO BOX 1539,CITY ACT 2601,

[REDACTED] 91 NORTHBOURNE AVENUE,BRADDON ACT 2612,

[REDACTED] 30/71 GILES STREET,KINGSTON ACT 2604,

TARMARC PTY LIMITED,PO BOX 7157,YARRALUMLA ACT 2600,

[REDACTED] 5 NORTH COURT PORT,NSW 2444,

[REDACTED] 25/71 GILES STREET,KINGSTON ACT 2604,

[REDACTED] PO BOX 3172,MANUKA ACT 2603,

[REDACTED] 8 WAGSTAFF PLACE,ISABELLA PLAINS ACT 2905,

[REDACTED] GPO BOX 1539,CANBERRA ACT 2601,

[REDACTED] 22 WYNN PLACE,FRASER ACT 2615,

PROPRIETORS UTP 3461,PO BOX 1539,CANBERRA CITY ACT 2601,

[REDACTED] GPO BOX 1539,CANBERRA BC ACT 2601,

[REDACTED] PO BOX 216,MITCHELL ACT 2911,

[REDACTED] 13/71 GILES STREET,KINGSTON ACT 2604,

[REDACTED] PO BOX 793,WODEN ACT 2606,

[REDACTED] 31/71 GILES STREET,KINGSTON ACT 2604,

[REDACTED] 31/71 GILES STREET,KINGSTON ACT 2604,

[REDACTED] 8 WAGSTAFF PLACE,ISABELLA PLAINS ACT 2905,

[REDACTED] 27 TARRANT CRESCENT,DUNLOP ACT 2615,

[REDACTED] PO BOX 66,GUNGAHLIN ACT 2912,
[REDACTED] 1/3 EUSTACE STREET,MANLY NSW 2095,
[REDACTED] 5 TURRIFF STREET,CHISHOLM ACT 2905,
[REDACTED] PO BOX 6233,KINGSTON ACT 2604,
[REDACTED] PO BOX 4589,KINGSTON ACT 2604,
[REDACTED] PO BOX 1086,COOMA NSW 2630,
[REDACTED] 4 MARTIN PLACE,BROULEE NSW 2537,
[REDACTED] 30/71 GILES STREET,KINGSTON ACT 2604,
[REDACTED] PO BOX 7005,KARABAR NSW 2620,
[REDACTED] 27/71 GILES STREET,KINGSTON ACT 2604,
JESMIC INVESTMENTS PTY LIMITED,PO BOX 5185,LYNEHAM ACT 2602,
IVCO HOLDINGS PTY LTD,PO BOX 4864,KINGSTON ACT 2604,
[REDACTED] 127 LANGDON AVENUE,WANNIASSA ACT 2903,
[REDACTED] PO BOX 5562,KINGSTON ACT 2604,
[REDACTED] 6/71 GILES STREET,KINGSTON ACT 2604,
[REDACTED] PO BOX 5044,KINGSTON ACT 2604,
[REDACTED] 11/71 GILES STREET,KINGSTON ACT 2604,
[REDACTED] GPO BOX 1539,CITY ACT 2601,
[REDACTED] PO BOX 609,CITY ACT 2608,
[REDACTED] 133 BODDINGTON CRESCENT,KAMBAH ACT 2902,
[REDACTED] GPO BOX 1539,CANBERRA BC ACT 2601,
[REDACTED] 5 TURRIFF STREET,CHISHOLM ACT 2905,
[REDACTED] 42/71 GILES STREET,KINGSTON ACT 2604,
[REDACTED] PO BOX 5695,HUGHES ACT 2605,
[REDACTED] 27 TARRANT CRESCENT,DUNLOP ACT 2615,
[REDACTED] 46/71 GILES STREET,KINGSTON ACT 2604,
[REDACTED] PO BOX 1539,CANBERRA ACT 2601,
[REDACTED] 55/71 GILES STREET,KINGSTON ACT 2604,
BRENNAN INVESTMENTS PTY LIMITED,GPO BOX 1539,CANBERRA ACT 2601,

[REDACTED] 43 CAMERON ROAD,QUEANBEYAN
NSW 2620,

[REDACTED] 1/3 EUSTACE STREET,MANLY NSW 2095,

[REDACTED] 383 ROSE VALLEY ROAD,COOMA NSW 2630,

[REDACTED] 63/71 GILES STREET,KINGSTON ACT 2604,

[REDACTED] 10 MUSGRAVE STREET,YARRALUMLA ACT 2600,

[REDACTED] PO BOX 4589,KINGSTON ACT 2604,

ARTICO HOLDINGS PTY LTD,PO BOX 4864,KINGSTON ACT 2604,

[REDACTED] 27 NOVAR STREET,YARRALUMLA ACT 2600,

[REDACTED] PO BOX 4658,KINGSTON ACT 2604,

the Resident,9/71 GILES STREET,KINGSTON ACT 2604,

the Resident,81/71 GILES STREET,KINGSTON ACT 2604,

the Resident,80/71 GILES STREET,KINGSTON ACT 2604,

the Resident,8/71 GILES STREET,KINGSTON ACT 2604,

the Resident,79/71 GILES STREET,KINGSTON ACT 2604,

the Resident,78/71 GILES STREET,KINGSTON ACT 2604,

the Resident,77/71 GILES STREET,KINGSTON ACT 2604,

the Resident,76/71 GILES STREET,KINGSTON ACT 2604,

the Resident,75/71 GILES STREET,KINGSTON ACT 2604,

the Resident,74/71 GILES STREET,KINGSTON ACT 2604,

the Resident,73/71 GILES STREET,KINGSTON ACT 2604,

the Resident,72/71 GILES STREET,KINGSTON ACT 2604,

the Resident,71/71 GILES STREET,KINGSTON ACT 2604,

the Resident,71 GILES STREET,KINGSTON ACT 2604,

the Resident,70/71 GILES STREET,KINGSTON ACT 2604,

the Resident,7/71 GILES STREET,KINGSTON ACT 2604,

the Resident,69/71 GILES STREET,KINGSTON ACT 2604,

the Resident,68/71 GILES STREET,KINGSTON ACT 2604,

the Resident,67/71 GILES STREET,KINGSTON ACT 2604,

the Resident,66/71 GILES STREET,KINGSTON ACT 2604,

the Resident,65/71 GILES STREET,KINGSTON ACT 2604,
the Resident,64/71 GILES STREET,KINGSTON ACT 2604,
the Resident,63/71 GILES STREET,KINGSTON ACT 2604,
the Resident,62/71 GILES STREET,KINGSTON ACT 2604,
the Resident,61/71 GILES STREET,KINGSTON ACT 2604,
the Resident,60/71 GILES STREET,KINGSTON ACT 2604,
the Resident,6/71 GILES STREET,KINGSTON ACT 2604,
the Resident,59/71 GILES STREET,KINGSTON ACT 2604,
the Resident,58/71 GILES STREET,KINGSTON ACT 2604,
the Resident,57/71 GILES STREET,KINGSTON ACT 2604,
the Resident,56/71 GILES STREET,KINGSTON ACT 2604,
the Resident,55/71 GILES STREET,KINGSTON ACT 2604,
the Resident,54/71 GILES STREET,KINGSTON ACT 2604,
the Resident,53/71 GILES STREET,KINGSTON ACT 2604,
the Resident,52/71 GILES STREET,KINGSTON ACT 2604,
the Resident,51/71 GILES STREET,KINGSTON ACT 2604,
the Resident,50/71 GILES STREET,KINGSTON ACT 2604,
the Resident,5/71 GILES STREET,KINGSTON ACT 2604,
the Resident,49/71 GILES STREET,KINGSTON ACT 2604,
the Resident,48/71 GILES STREET,KINGSTON ACT 2604,
the Resident,47/71 GILES STREET,KINGSTON ACT 2604,
the Resident,46/71 GILES STREET,KINGSTON ACT 2604,
the Resident,45/71 GILES STREET,KINGSTON ACT 2604,
the Resident,44/71 GILES STREET,KINGSTON ACT 2604,
the Resident,43/71 GILES STREET,KINGSTON ACT 2604,
the Resident,42/71 GILES STREET,KINGSTON ACT 2604,
the Resident,41/71 GILES STREET,KINGSTON ACT 2604,
the Resident,40/71 GILES STREET,KINGSTON ACT 2604,
the Resident,4/71 GILES STREET,KINGSTON ACT 2604,
the Resident,39/71 GILES STREET,KINGSTON ACT 2604,

the Resident,38/71 GILES STREET,KINGSTON ACT 2604,
the Resident,37/71 GILES STREET,KINGSTON ACT 2604,
the Resident,36/71 GILES STREET,KINGSTON ACT 2604,
the Resident,35/71 GILES STREET,KINGSTON ACT 2604,
the Resident,34/71 GILES STREET,KINGSTON ACT 2604,
the Resident,33/71 GILES STREET,KINGSTON ACT 2604,
the Resident,32/71 GILES STREET,KINGSTON ACT 2604,
the Resident,31/71 GILES STREET,KINGSTON ACT 2604,
the Resident,30/71 GILES STREET,KINGSTON ACT 2604,
the Resident,3/71 GILES STREET,KINGSTON ACT 2604,
the Resident,29/71 GILES STREET,KINGSTON ACT 2604,
the Resident,28/71 GILES STREET,KINGSTON ACT 2604,
the Resident,27/71 GILES STREET,KINGSTON ACT 2604,
the Resident,26/71 GILES STREET,KINGSTON ACT 2604,
the Resident,25/71 GILES STREET,KINGSTON ACT 2604,
the Resident,24/71 GILES STREET,KINGSTON ACT 2604,
the Resident,23/71 GILES STREET,KINGSTON ACT 2604,
the Resident,22/71 GILES STREET,KINGSTON ACT 2604,
the Resident,21/71 GILES STREET,KINGSTON ACT 2604,
the Resident,20/71 GILES STREET,KINGSTON ACT 2604,
the Resident,2/71 GILES STREET,KINGSTON ACT 2604,
the Resident,19/71 GILES STREET,KINGSTON ACT 2604,
the Resident,18/71 GILES STREET,KINGSTON ACT 2604,
the Resident,17/71 GILES STREET,KINGSTON ACT 2604,
the Resident,16/71 GILES STREET,KINGSTON ACT 2604,
the Resident,15/71 GILES STREET,KINGSTON ACT 2604,
the Resident,14/71 GILES STREET,KINGSTON ACT 2604,
the Resident,13/71 GILES STREET,KINGSTON ACT 2604,
the Resident,12/71 GILES STREET,KINGSTON ACT 2604,
the Resident,11/71 GILES STREET,KINGSTON ACT 2604,

the Resident,10/71 GILES STREET,KINGSTON ACT 2604,

the Resident,1/71 GILES STREET,KINGSTON ACT 2604,

[REDACTED] 54/61 GILES STREET,KINGSTON ACT 2604,

[REDACTED] 35 BARRALLIER STREET,GRIFFITH ACT 2603,

[REDACTED] 24 HENSLOWE PLACE,MELBA ACT 2615,

[REDACTED] P O BOX 4267,KINGSTON ACT 2604,

[REDACTED] PO BOX 4589,KINGSTON ACT 2604,

[REDACTED] 37/61-63 GILES STREET,KINGSTON ACT 2604,

TUCKER MANAGEMENT PTY LTD,PO BOX 4305,KINGSTON ACT 2604,

[REDACTED] PO BOX 4351,KINGSTON ACT 2604,

THE OWNERS-UNITS PLAN NO 2728,LOCKED BAG 6,DEAKIN ACT 2600,

[REDACTED] 3 MEEHAN GARDENS,GRIFFITH ACT 2603,

[REDACTED] 98/61 GILES STREET,KINGSTON ACT 2604,

[REDACTED] 8/67 GILES STREET,KINGSTON ACT 2604,

[REDACTED] 40/61-63 GILES STREET,KINGSTON ACT 2604,

[REDACTED] PO BOX 4589,KINGSTON ACT 2604,

[REDACTED] 57/65 GILES STREET,KINGSTON ACT 2604,

[REDACTED] 5/65 GILES STREET,KINGSTON ACT 2604,

[REDACTED] 7 WANAWONG COURT NORTH
TERRACE,JERRABOMBERRA NSW 2619,

[REDACTED] 146 COOMA STREET,QUEANBEYAN NSW 2620,

[REDACTED] 105/65 GILES STREET,KINGSTON ACT 2604,

[REDACTED] 8/67 GILES STREET,KINGSTON ACT 2604,

[REDACTED] 19 SHEEHAN STREET,PEARCE ACT 2607,

[REDACTED] 101/61 GILES STREET,KINGSTON ACT 2604,

[REDACTED] PO BOX 621,ERINDALE ACT 2903,

[REDACTED] PO BOX 119,WEST WYALONG NSW 2671,

[REDACTED] PO BOX 621,ERINDALE ACT 2903,

[REDACTED] 63 GILES STREET,KINGSTON ACT 2604,

[REDACTED] PO BOX 3788,MANUKA ACT 2603,

[REDACTED] 54/61 GILES STREET,KINGSTON ACT 2604,
[REDACTED] 102/63 GILES STREET,KINGSTON ACT
2604,
[REDACTED] 95/61 GILES STREET,KINGSTON ACT 2604,
[REDACTED] 7/67 GILES STREET,KINGSTON ACT 2604,
[REDACTED] 95/61 GILES STREET,KINGSTON ACT 2604,
[REDACTED] PO BOX 621,ERINDALE CENTRE ACT 2903,
[REDACTED] 59/14 NATIONAL CIRCUIT,BARTON ACT 2600,
[REDACTED] PO BOX 5283,KINGSTON ACT 2604,
[REDACTED] 103/63 GILES STREET,KINGSTON ACT 2604,
[REDACTED] PO BOX 5283,KINGSTON ACT 2604,
[REDACTED] 7 STOKES STREET,GRIFFITH ACT 2603,
[REDACTED] PO BOX 5283,KINGSTON ACT 2604,
[REDACTED] PO BOX Q110,QUEEN VICTORIA BUILDING NSW 1230,
[REDACTED] GPO BOX 3141,MANUKA ACT 2603,
[REDACTED] 99/61 GILES STREET,KINGSTON ACT 2604,
[REDACTED] 22 MURRUBA STREET,JERRABOMBERRA NSW 2619,
[REDACTED] 11 BLAXLAND CRESCENT,GRIFFITH ACT 2603,
[REDACTED] 33 JARDINE STREET,KINGSTON ACT 2604,
[REDACTED] GPO BOX 1271,MELBOURNE VIC,
[REDACTED] 99/61 GILES STREET,KINGSTON ACT 2604,
[REDACTED] PO BOX 4589,KINGSTON ACT 2604,
[REDACTED] PO BOX 3785,MANUKA ACT 2603,
[REDACTED] 3 MEEHAN GARDENS,GRIFFITH ACT 2603,
[REDACTED] 44 FOOTE STREET,ALBERT PARK VIC 3206,
[REDACTED] PO BOX 621,ERINDALE CENTRE ACT 2903,
[REDACTED] PO BOX 4321,KINGSTON ACT 2604,
[REDACTED] 12 HOTHAM CRESCENT,DEAKIN ACT 2600,
[REDACTED] 21/442-446 EDGECLIFF ROAD,EDGECLIFF NSW 2027,
[REDACTED] PO BOX 3785,MANUKA ACT 2603,

P O BOX 4267,KINGSTON ACT 2604,

the Resident,I-63 GILES STREET,KINGSTON ACT 2604,
the Resident,9/61-63 GILES STREET,KINGSTON ACT 2604,
the Resident,8/61-63 GILES STREET,KINGSTON ACT 2604,
the Resident,7/61-63 GILES STREET,KINGSTON ACT 2604,
the Resident,61-63 GILES STREET,KINGSTON ACT 2604,
the Resident,6/61-63 GILES STREET,KINGSTON ACT 2604,
the Resident,5/61-63 GILES STREET,KINGSTON ACT 2604,
the Resident,45/61-63 GILES STREET,KINGSTON ACT 2604,
the Resident,44/61-63 GILES STREET,KINGSTON ACT 2604,
the Resident,43/61-67 GILES STREET,KINGSTON ACT 2604,
the Resident,42/61-63 GILES STREET,KINGSTON ACT 2604,
the Resident,41/-67 GILES STREET,KINGSTON ACT 2604,
the Resident,40/61-63 GILES STREET,KINGSTON ACT 2604,
the Resident,4/61-63 GILES STREET,KINGSTON ACT 2604,
the Resident,39/61-63 GILES STREET,KINGSTON ACT 2604,
the Resident,38/61-63 GILES STREET,KINGSTON ACT 2604,
the Resident,37/61-63 GILES STREET,KINGSTON ACT 2604,
the Resident,36/61-63 GILES STREET,KINGSTON ACT 2604,
the Resident,35/61-63 GILES STREET,KINGSTON ACT 2604,
the Resident,34/61-63 GILES STREET,KINGSTON ACT 2604,
the Resident,33/61-63 GILES STREET,KINGSTON ACT 2604,
the Resident,32/61-63 GILES STREET,KINGSTON ACT 2604,
the Resident,31/61-63 GILES STREET,KINGSTON ACT 2604,
the Resident,30/61-63 GILES STREET,KINGSTON ACT 2604,
the Resident,3/61-63 GILES STREET,KINGSTON ACT 2604,
the Resident,29/61-63 GILES STREET,KINGSTON ACT 2604,
the Resident,28/61-63 GILES STREET,KINGSTON ACT 2604,
the Resident,27/61-63 GILES STREET,KINGSTON ACT 2604,
the Resident,26/61-63 GILES STREET,KINGSTON ACT 2604,

the Resident,24/61-63 GILES STREET,KINGSTON ACT 2604,
the Resident,23/61-63 GILES STREET,KINGSTON ACT 2604,
the Resident,22/61-63 GILES STREET,KINGSTON ACT 2604,
the Resident,21/61-63 GILES STREET,KINGSTON ACT 2604,
the Resident,20/61-63 GILES STREET,KINGSTON ACT 2604,
the Resident,2/61-63 GILES STREET,KINGSTON ACT 2604,
the Resident,19/63 GILES STREET,KINGSTON ACT 2604,
the Resident,18/61-63 GILES STREET,KINGSTON ACT 2604,
the Resident,17/61-63 GILES STREET,KINGSTON ACT 2604,
the Resident,16/61-63 GILES STREET,KINGSTON ACT 2604,
the Resident,15/61-63 GILES STREET,KINGSTON ACT 2604,
the Resident,14/61-63 GILES STREET,KINGSTON ACT 2604,
the Resident,13/61-63 GILES STREET,KINGSTON ACT 2604,
the Resident,12/61-63 GILES STREET,KINGSTON ACT 2604,
the Resident,11/61-63 GILES STREET,KINGSTON ACT 2604,
the Resident,10/61-63 GILES STREET,KINGSTON ACT 2604,
the Resident,1/61-63 GILES STREET,KINGSTON ACT 2604,

[REDACTED] PO BOX 3512,MANUKA ACT 2603,

the Resident,6/41-53 GILES STREET,KINGSTON ACT 2604,

the Resident,5/43-51 GILES STREET,KINGSTON ACT 2604,

[REDACTED] 30 NARRAWA PLACE,BEGA NSW 2550,

[REDACTED] 1/43 GILES STREET,KINGSTON ACT 2604,

[REDACTED] GPO BOX 1271,MELBOURNE VIC 3001,

[REDACTED] 27/51 GILES STREET,KINGSTON ACT 2604,

[REDACTED] 9 LOCKYER STREET,GRIFFITH ACT 2603,

[REDACTED] PO BOX 5031,GARRAN ACT 2605,

[REDACTED] GPO BOX 1271,MELBOURNE VIC 3001,

THE OWNERS - UNITS PLAN NO 666,43-51 GILES STREET,KINGSTON ACT 2604,

[REDACTED] 16 SURFERS PARADE,THIRROUL NSW 2515,

[REDACTED] 86 BANKS STREET,YARRALUMLA ACT 2600,

[REDACTED] 39/41-53 GILES STREET,KINGSTON ACT 2604,
[REDACTED] PO BOX 4487,KINGSTON ACT 2604,
[REDACTED] UNIT 26A WENTWORTH CIRCUIT,KINGSTON ACT 2604,
[REDACTED] 23/0 WENTWORTH CIRCUIT,KINGSTON ACT 2604,
[REDACTED] 54 SHARWOOD CRESCENT,EVATT ACT 2617,
[REDACTED] PO BOX 922,BELCONNEN ACT 2616,
PETER D ELLIS PTY LTD,PO BOX 6552,EAST PERTH WA 6892,
[REDACTED] GPO BOX 1271,MELBOURNE VIC 3001,
[REDACTED] PO BOX 7017,CANBERRA BC ACT 2610,
[REDACTED] GPO BOX 1271,MELBOURNE VIC 3001,
[REDACTED] PO BOX 3387,MANUKA ACT 2603,
[REDACTED] 41 CURLEWIS CRESCENT,GARRAN ACT 2605,
[REDACTED] 4A/43-51 GILES STREET,KINGSTON ACT 2604,
[REDACTED] 8/43-51 GILES STREET,KINGSTON ACT 2604,
[REDACTED] 100 CAPTAIN COOK CRESCENT,NARRABUNDAH ACT 2604,
[REDACTED] 10/7 LANE-POOLE PLACE,YARRALUMLA ACT 2600,
[REDACTED] GPO BOX 1271,MELBOURNE VIC 3001,
the Resident,9/43-51 GILES STREET,KINGSTON ACT 2604,
the Resident,8/43-51 GILES STREET,KINGSTON ACT 2604,
the Resident,7/43-51 GILES STREET,KINGSTON ACT 2604,
[REDACTED] 11/1 GOLDMAN STREET,BRUCE ACT 2617,
[REDACTED] 4A/43-51 GILES STREET,KINGSTON ACT 2604,
[REDACTED] 17 PERRY DRIVE,CHAPMAN ACT 2611,
[REDACTED] 22/51 GILES STREET,KINGSTON ACT 2604,
[REDACTED] PO BOX 3788,MANUKA ACT 2603,
the Resident,4/43-51 GILES STREET,KINGSTON ACT 2604,
the Resident,3/43-51 GILES STREET,KINGSTON ACT 2604,
[REDACTED] 100 CAPTAIN COOK CRESCENT,NARRABUNDAH ACT 2604,
[REDACTED] 22/51 GILES STREET,KINGSTON ACT 2604,
[REDACTED] 15/43-51 GILES STREET,KINGSTON ACT 2604,

[REDACTED] 11 WENTWORTH COURT 51 GILES STREET,KINGSTON ACT 2604,

[REDACTED] 40/41-53 GILES STREET,KINGSTON ACT 2604,

[REDACTED] PO BOX 823 ,MORUYA NSW 2537,

[REDACTED] 9 BEAVER STREET,MALVERN EAST VIC 3145,

[REDACTED] PO BOX 3512,MANUKA ACT 2603,

[REDACTED] PO BOX 2209,ORANGE NSW 2800,

[REDACTED] 16 SURFERS PARADE,THIRROUL NSW 2515,

[REDACTED] 15A WENTWORTH CIRCUIT,KINGSTON ACT 2604,

[REDACTED] 16 CLARE DENNIS AVENUE,GORDON ACT 2906,

[REDACTED] 27 ARTHUR CIRCUIT,GRIFFITH ACT 2603,

[REDACTED] 14/43-51 GILES STREET,KINGSTON ACT 2604,

[REDACTED] PO BOX 4267,KINGSTON ACT 2604,

[REDACTED] 10/43-51 GILES STREET,KINGSTON ACT 2604,

[REDACTED] 17A/43-51 GILES STREET,KINGSTON ACT 2604,

[REDACTED] GPO BOX 1271,MELBOURNE VIC 3001,

[REDACTED] 40/41-53 GILES STREET,KINGSTON ACT 2604,

[REDACTED] 17A/43-51 GILES STREET,KINGSTON ACT 2604,

[REDACTED] 13A/43-51 GILES STREET,KINGSTON ACT 2604,

[REDACTED] UNIT 19A WENTWORTH CIRCUIT,KINGSTON ACT 2604,

[REDACTED] PO BOX 5044,KINGSTON ACT 2604,

[REDACTED] 27/51 GILES STREET,KINGSTON ACT 2604,

[REDACTED] 7/32 LONSDALE STREET,BRADDON ACT 2612,

the Resident,49/41-53 GILES STREET,KINGSTON ACT 2604,

[REDACTED] 11 WENTWORTH COURT 51 GILES STREET,KINGSTON ACT 2604,

the Resident,48/41-53 GILES STREET,KINGSTON ACT 2604,

the Resident,47/43-51 GILES STREET,KINGSTON ACT 2604,

the Resident,46/43-51 GILES STREET,KINGSTON ACT 2604,

the Resident,45/43 GILES STREET,KINGSTON ACT 2604,

the Resident,44/43-51 GILES STREET,KINGSTON ACT 2604,

the Resident,43/41-53 GILES STREET,KINGSTON ACT 2604,

the Resident,42/41-53 GILES STREET,KINGSTON ACT 2604,
the Resident,41/41-53 GILES STREET,KINGSTON ACT 2604,
the Resident,40/41-53 GILES STREET,KINGSTON ACT 2604,
the Resident,39/41-53 GILES STREET,KINGSTON ACT 2604,
the Resident,38/41-53 GILES STREET,KINGSTON ACT 2604,
the Resident,37/41-53 GILES STREET,KINGSTON ACT 2604,
the Resident,36/43-51 GILES STREET,KINGSTON ACT 2604,
the Resident,35/43-51 GILES STREET,KINGSTON ACT 2604,
the Resident,34/43-51 GILES STREET,KINGSTON ACT 2604,
the Resident,33/43-51 GILES STREET,KINGSTON ACT 2604,
the Resident,32/43-51 GILES STREET,KINGSTON ACT 2604,
the Resident,31/43-51 GILES STREET,KINGSTON ACT 2604,
the Resident,30/43-51 GILES STREET,KINGSTON ACT 2604,
the Resident,29/43-51 GILES STREET,KINGSTON ACT 2604,
the Resident,28/43-51 GILES STREET,KINGSTON ACT 2604,
the Resident,27/43-51 GILES STREET,KINGSTON ACT 2604,
the Resident,26/43-51 GILES STREET,KINGSTON ACT 2604,
the Resident,25/43 GILES STREET,KINGSTON ACT 2604,
the Resident,24/43-51 GILES STREET,KINGSTON ACT 2604,
the Resident,23/43 GILES STREET,KINGSTON ACT 2604,
the Resident,22/43-51 GILES STREET,KINGSTON ACT 2604,
the Resident,21/41-53 GILES STREET,KINGSTON ACT 2604,
the Resident,20/41-53 GILES STREET,KINGSTON ACT 2604,
the Resident,2/43-51 GILES STREET,KINGSTON ACT 2604,
the Resident,19/41-53 GILES STREET,KINGSTON ACT 2604,
the Resident,18/41-53 GILES STREET,KINGSTON ACT 2604,
the Resident,17/43-51 GILES STREET,KINGSTON ACT 2604,
the Resident,16/41-53 GILES STREET,KINGSTON ACT 2604,
the Resident,15/43-51 GILES STREET,KINGSTON ACT 2604,
the Resident,14/41-53 GILES STREET,KINGSTON ACT 2604,

the Resident,13/43-51 GILES STREET,KINGSTON ACT 2604,

the Resident,12/41-53 GILES STREET,KINGSTON ACT 2604,

the Resident,11/41-53 GILES STREET,KINGSTON ACT 2604,

the Resident,10/43-51 GILES STREET,KINGSTON ACT 2604,

the Resident,1/43 GILES STREET,KINGSTON ACT 2604,

[REDACTED] 13/36 GOSSE STREET,KINGSTON ACT 2604,

THE OWNERS - UNITS PLAN NO 394,LOCKED BAG 6,DEAKIN ACT 2600,

[REDACTED] PO BOX 3788,MANUKA ACT 2603,

[REDACTED] U7/36 GOSSE STREET,KINGSTON ACT 2604,

[REDACTED] PO BOX 4900,KINGSTON ACT 2604,

[REDACTED] 6/36 GOSSE STREET,KINGSTON ACT 2604,

[REDACTED] 28 THRELFALL STREET,CHIFLEY ACT 2606,

[REDACTED] 20/36 GOSSE STREET,KINGSTON ACT 2604,

[REDACTED] 15/36 GOSSE STREET,KINGSTON ACT 2604,

[REDACTED] 21/36 GOSSE STREET,KINGSTON ACT 2604,

[REDACTED] PO BOX 3956,MANUKA ACT 2603,

[REDACTED] 12/36 GOSSE STREET,KINGSTON ACT 2604,

[REDACTED] PO BOX 5130,KINGSTON ACT 2604,

[REDACTED] PO BOX 3956,MANUKA ACT 2603,

[REDACTED] U7/36 GOSSE STREET,KINGSTON ACT 2604,

[REDACTED] 20/36 GOSSE STREET,KINGSTON ACT 2604,

[REDACTED] PO BOX 3956,MANUKA ACT 2603,

[REDACTED] 15/36 GOSSE STREET,KINGSTON ACT 2604,

[REDACTED] 6 EWART STREET,YARRALUMLA ACT 2600,

[REDACTED] PO BOX 5546,KINGSTON ACT 2604,

[REDACTED] 9/36 GOSSE STREET,KINGSTON ACT 2604,

[REDACTED] 5/36 GOSSE STREET,KINGSTON ACT 2604,

[REDACTED] PO BOX 5546,KINGSTON ACT 2604,

[REDACTED] 47 WHITE CRESCENT,CAMPBELL ACT 2612,

[REDACTED] PO BOX 4033,KINGSTON ACT 2604,

[REDACTED] PO BOX 5044,KINGSTON ACT 2604,

[REDACTED] PO BOX 3956,MANUKA ACT 2603,

the Resident,9/36 GOSSE STREET,KINGSTON ACT 2604,

[REDACTED] 8/36 GOSSE STREET,KINGSTON ACT 2604,

[REDACTED] PO BOX 1224,COOMA NSW 2630,

the Resident,7/36 GOSSE STREET,KINGSTON ACT 2604,

the Resident,6/36 GOSSE STREET,KINGSTON ACT 2604,

the Resident,5/36 GOSSE STREET,KINGSTON ACT 2604,

the Resident,4/36 GOSSE STREET,KINGSTON ACT 2604,

the Resident,36 GOSSE STREET,KINGSTON ACT 2604,

the Resident,3/36 GOSSE STREET,KINGSTON ACT 2604,

the Resident,23/36 GOSSE STREET,KINGSTON ACT 2604,

the Resident,22/36 GOSSE STREET,KINGSTON ACT 2604,

the Resident,21/36 GOSSE STREET,KINGSTON ACT 2604,

the Resident,20/36 GOSSE STREET,KINGSTON ACT 2604,

the Resident,2/36 GOSSE STREET,KINGSTON ACT 2604,

the Resident,19/36 GOSSE STREET,KINGSTON ACT 2604,

the Resident,18/36 GOSSE STREET,KINGSTON ACT 2604,

the Resident,17/36 GOSSE STREET,KINGSTON ACT 2604,

the Resident,16/36 GOSSE STREET,KINGSTON ACT 2604,

the Resident,15/36 GOSSE STREET,KINGSTON ACT 2604,

the Resident,14/36 GOSSE STREET,KINGSTON ACT 2604,

the Resident,13/36 GOSSE STREET,KINGSTON ACT 2604,

the Resident,12/36 GOSSE STREET,KINGSTON ACT 2604,

the Resident,11/36 GOSSE STREET,KINGSTON ACT 2604,

the Resident,10/36 GOSSE STREET,KINGSTON ACT 2604,

the Resident,1/36 GOSSE STREET,KINGSTON ACT 2604,

GREEK ORTHODOX COMMUNITY AND CHURCH OF CANBERRA AND DISTRICT
INCORPORATED,GPO BOX 208,CANBERRA ACT 2601,

the Resident,1 GOSSE STREET,KINGSTON ACT 2604,

the Resident,2 WENTWORTH AVENUE,KINGSTON ACT 2604,

THE GREEK ORTHODOX COMMUNITY AND CHURCH OF CANBERRA AND DISTRICT
INCORPORATED,1 GOSSE STREET,KINGSTON ACT 2604,

the Resident,81 GILES STREET,KINGSTON ACT 2604,

CLANCY (ACT) PTY LTD,59 WENTWORTH AVENUE,KINGSTON ACT 2604,

ENGLOBO GROUP VENTURE NO 1 PTY LTD,103-105 NORTHBOURNE AVENUE,BRADDON ACT
2612,

the Resident, EASTLAKE PARADE,KINGSTON ACT 2604,

ZOG PTY LTD,3/37 TELOPEA PARK,BARTON ACT 2600,

[REDACTED] GPO BOX 749,CANBERRA BC ACT 2610,

[REDACTED] 11/7 EASTLAKE PARADE,KINGSTON ACT,

[REDACTED] 79/13 EASTLAKE PARADE,KINGSTON ACT 2604,

[REDACTED] 29/9 EASTLAKE PARADE,KINGSTON ACT 2604,

[REDACTED] PO BOX 5575,KINGSTON ACT 2604,

[REDACTED] PO BOX 4589,KINGSTON ACT 2604,

[REDACTED] PO BOX 3566,MANUKA ACT 2603,

[REDACTED] 909/19 MARCUS CLARKE STREET,CITY ACT 2601,

[REDACTED] 5/7 EASTLAKE PARADE,KINGSTON ACT 2604,

[REDACTED] 36/9 EASTLAKE PARADE,KINGSTON ACT 2604,

[REDACTED] PO BOX 906,POTTS POINT NSW 1335,

[REDACTED] 43/9 EASTLAKE PARADE,KINGSTON ACT 2604,

[REDACTED] PO BOX 5044,KINGSTON ACT 2604,

THE OWNERS-UNITS PLAN NO 3107,37/9 EASTLAKE PARADE,KINGSTON ACT 2604,

[REDACTED] PO BOX 4589,KINGSTON ACT 2604,

[REDACTED] PO BOX 6057,KINGSTON ACT 2604,

[REDACTED] 71/11 EASTLAKE PARADE,KINGSTON ACT 2604,

[REDACTED] PO BOX 19,CENTRAL TILBA NSW 2546,

[REDACTED] PO BOX 4589,KINGSTON ACT 2604,

[REDACTED] 85/13 EASTLAKE PARADE,KINGSTON ACT 2604,

[REDACTED] 5 MORESBY STREET,FORREST ACT 2603,

[REDACTED] 47/9 EASTLAKE PARADE,KINGSTON ACT 2604,

[REDACTED] PO BOX 3788,MANUKA ACT 2603,
[REDACTED] 102/13 EASTLAKE PARADE,KINGSTON ACT 2604,
[REDACTED] 58 MACKENZIE STREET,HACKETT ACT 2602,
[REDACTED] 14 SCHLICH STREET,YARRALUMLA
ACT 2600,
[REDACTED] PO BOX 4313,KINGSTON ACT 2604,
[REDACTED] PO BOX 4589,KINGSTON ACT 2604,
[REDACTED] PO BOX 3785,MANUKA ACT 2603,
[REDACTED] 15/7 EASTLAKE PARADE,KINGSTON ACT 2604,
[REDACTED] 39/9 EASTLAKE PARADE,KINGSTON ACT 2604,
[REDACTED] GPO BOX 822,CANBERRA ACT 2601,
[REDACTED] 27/9 EASTLAKE PARADE,KINGSTON ACT 2604,
[REDACTED] 27 BOUGAINVILLE STREET,MANUKA ACT 2603,
[REDACTED] GPO BOX 822,CANBERRA ACT 2601,
[REDACTED] PO BOX 3301,WESTON CREEK ACT 2611,
[REDACTED] PO BOX 509,BURNIE TAS 7320,
[REDACTED] 91/13 EASTLAKE PARADE,KINGSTON ACT 2604,
[REDACTED] PO BOX 5044,KINGSTON ACT 2604,
[REDACTED] 49/9 EASTLAKE PARADE,KINGSTON ACT 2604,
[REDACTED] PO BOX 6046,KINGSTON ACT 2604,
[REDACTED] 13 MEEHAN GARDENS,GRIFFITH ACT 2603,
the Resident,5/7 EASTLAKE PARADE,KINGSTON ACT 2604,
the Resident,4/7 EASTLAKE PARADE,KINGSTON ACT 2604,
[REDACTED] 3/7 EASTLAKE PARADE,KINGSTON ACT 2604,
[REDACTED] PO BOX 4004,WESTON CREEK ACT 2611,
[REDACTED] PO BOX 439,MITCHELL ACT 2911,
[REDACTED] 22 DOMINION CIRCUIT,FORREST ACT 2603,
[REDACTED] 7 BAVDIN STREET,FORREST ACT 2603,
[REDACTED] 7 BAUDIN STREET,FORREST ACT 2603,
[REDACTED] 7 BAUDIN CRESCENT,FORREST ACT 2603,

[REDACTED] 28 BOUGAINVILLE STREET, MANUKA ACT 2603,
[REDACTED] 33/9 EASTLAKE PARADE, KINGSTON ACT 2604,
[REDACTED] 16/7 EASTLAKE PARADE, KINGSTON ACT
2604,
[REDACTED] 49/9 EASTLAKE PARADE, KINGSTON ACT 2604,
[REDACTED] 34/9 EASTLAKE PARADE, KINGSTON ACT 2604,
[REDACTED]
[REDACTED] PO BOX 3788, MANUKA ACT 2603,
[REDACTED] 87/13 EASTLAKE
PARADE, KINGSTON ACT 2604,
[REDACTED] 39/9 EASTLAKE PARADE, KINGSTON ACT 2604,
[REDACTED] PO BOX 4037, KINGSTON ACT 2604,
[REDACTED] 98/13 EASTLAKE PARADE, KINGSTON ACT
2604,
[REDACTED] 68 , KINGSTON ACT 2604,
[REDACTED] 76/11 EASTLAKE PARADE, KINGSTON ACT
2604,
[REDACTED] PO BOX 1209, BROOKVALE NSW 2100,
[REDACTED] 33/9 EASTLAKE PARADE, KINGSTON ACT 2604,
[REDACTED] 20/7 EASTLAKE PARADE, KINGSTON ACT 2604,
[REDACTED] 28 BOUGAINVILLE STREET, MANUKA ACT 2603,
[REDACTED] PO BOX 3387, MANUKA ACT 2603,
[REDACTED] 60/11 EASTLAKE PARADE, KINGSTON ACT 2604,
J [REDACTED] 104/0 NORTHPOINT PLAZA, BELCONNEN DC ACT 2617,
[REDACTED] 22/7 EASTLAKE PARADE, KINGSTON ACT
2604,
[REDACTED] PO BOX 3387, MANUKA ACT 2603,
[REDACTED] 21/7 EASTLAKE PARADE, KINGSTON ACT
2604,
[REDACTED] PO BOX 3301, WESTON CREEK ACT 2611,
[REDACTED] PO BOX 4037, KINGSTON ACT 2604,
[REDACTED] 57 CORANDERRK STREET, REID ACT 2612,
[REDACTED] 23/7 EASTLAKE PARADE, KINGSTON ACT 2604,

HALFWAY CREEK SUPERANNUATION PTY LTD,113 CANBERRA AVENUE,GRIFFITH ACT 2603,

[REDACTED] PO BOX 5044,KINGSTON ACT 2604,

[REDACTED] BOX 6177,KINGSTON ACT 2604,

[REDACTED] 3 SCOTT STREET,NARRABUNDAH ACT 2604,

GLOBAL STRATEGIES PTY LTD,72/11 EASTLAKE PARADE,KINGSTON ACT 2604,

GLOBAL STRATEGIES PTY LTD,72/11 EASTLAKE PARADE,KINGSTON ACT 2604,

[REDACTED] U88 13 EASTLAKE PARADE,KINGSTON ACT 2604,

J [REDACTED] 53/11 EASTLAKE PARADE,KINGSTON ACT 2604,

[REDACTED] PO BOX 4589,KINGSTON ACT 2604,

[REDACTED] 54/11 EASTLAKE PARADE,KINGSTON ACT 2604,

[REDACTED] 30/9 EASTLAKE PARADE,KINGSTON ACT 2604,

[REDACTED] 26/7 EASTLAKE PARADE,KINGSTON ACT 2604,

[REDACTED] 64/11 EASTLAKE PARADE,KINGSTON ACT 2604,

[REDACTED] PO BOX 6215,O`CONNOR ACT 2602,

[REDACTED] 12/7 EASTLAKE PARADE,KINGSTON ACT 2604,

[REDACTED] PO BOX 6215,O`CONNOR ACT 2602,

[REDACTED] 34/9 EASTLAKE PARADE,KINGSTON ACT 2604,

[REDACTED] 15 DUCANE STREET,FORREST ACT 2603,

[REDACTED] PO BOX 118,CAMPBELL ACT 2612,

[REDACTED] 93/13 EASTLAKE PARADE,KINGSTON ACT 2604,

[REDACTED] 38/9 EASTLAKE PARADE,KINGSTON ACT 2604,

[REDACTED] PO BOX 4589,KINGSTON ACT 2604,

[REDACTED] PO BOX 4317,KINGSTON ACT 2604,

[REDACTED] 38/9 EASTLAKE PARADE,KINGSTON ACT 2604,

[REDACTED] U83/13 EASTLAKE PARADE,KINGSTON ACT 2604,

[REDACTED] 90 CORRINYAH STREET,GOULBURN NSW 2580,

[REDACTED] 55/11 EASTLAKE PARADE,KINGSTON ACT 2604,

[REDACTED] PO BOX 3956,MANUKA ACT 2603,

[REDACTED] PO BOX 3512,MANUKA ACT 2603,

[REDACTED] PO BOX 3788,MANUKA ACT 2603,

the Resident,9/7 EASTLAKE PARADE,KINGSTON ACT 2604,

[REDACTED] 6 HAMELIN CRESCENT,NARRABUNDAH ACT 2604,

[REDACTED] 58/11 EASTLAKE PARADE,KINGSTON ACT 2604,

[REDACTED] 27 MUELLER STREET,YARRALUMLA ACT 2600,

[REDACTED] PO BOX 4313,KINGSTON ACT 2604,

[REDACTED] 44/9 EASTLAKE PARADE,KINGSTON ACT 2604,

the Resident,8/7 EASTLAKE PARADE,KINGSTON ACT 2604,

the Resident,7/7 EASTLAKE PARADE,KINGSTON ACT 2604,

the Resident,6/7 EASTLAKE PARADE,KINGSTON ACT 2604,

[REDACTED] 33 JARDINE STREET,KINGSTON ACT 2604,

[REDACTED] 40/9 EASTLAKE PARADE,KINGSTON ACT 2604,

[REDACTED] 81 MOUNTAIN VALE ROAD,MURRUMBATEMAN NSW 2582,

[REDACTED] 28/9 EASTLAKE PARADE,KINGSTON ACT 2604,

[REDACTED] PO BOX 4589,KINGSTON ACT 2604,

[REDACTED] 103/13 EASTLAKE PARADE,KINGSTON ACT 2604,

the Resident,23/7 EASTLAKE PARADE,KINGSTON ACT 2604,

the Resident,22/7 EASTLAKE PARADE,KINGSTON ACT 2604,

the Resident,21/7 EASTLAKE PARADE,KINGSTON ACT 2604,

the Resident,20/7 EASTLAKE PARADE,KINGSTON ACT 2604,

[REDACTED] 15/7 EASTLAKE PARADE,KINGSTON ACT 2604,

[REDACTED] U24 / 7 EASTLAKE PARADE,KINGSTON ACT 2604,

[REDACTED] PO BOX 4317,KINGSTON ACT 2604,

AJC PROPERTY GROUP PTY LTD,1/17 DUNDAS CIRCUIT,PHILLIP ACT 2606,

the Resident,99/13 EASTLAKE PARADE,KINGSTON ACT 2604,

the Resident,98/13 EASTLAKE PARADE,KINGSTON ACT 2604,

the Resident,97/13 EASTLAKE PARADE,KINGSTON ACT 2604,

the Resident,96/13 EASTLAKE PARADE,KINGSTON ACT 2604,

the Resident,95/13 EASTLAKE PARADE,KINGSTON ACT 2604,

the Resident,94/13 EASTLAKE PARADE,KINGSTON ACT 2604,

the Resident,93/13 EASTLAKE PARADE,KINGSTON ACT 2604,
the Resident,92/13 EASTLAKE PARADE,KINGSTON ACT 2604,
the Resident,91/13 EASTLAKE PARADE,KINGSTON ACT 2604,
the Resident,90/13 EASTLAKE PARADE,KINGSTON ACT 2604,
the Resident,89/13 EASTLAKE PARADE,KINGSTON ACT 2604,
the Resident,88/13 EASTLAKE PARADE,KINGSTON ACT 2604,
the Resident,87/13 EASTLAKE PARADE,KINGSTON ACT 2604,
the Resident,86/13 EASTLAKE PARADE,KINGSTON ACT 2604,
the Resident,85/13 EASTLAKE PARADE,KINGSTON ACT 2604,
the Resident,84/13 EASTLAKE PARADE,KINGSTON ACT 2604,
the Resident,83/13 EASTLAKE PARADE,KINGSTON ACT 2604,
the Resident,82/13 EASTLAKE PARADE,KINGSTON ACT 2604,
the Resident,81/13 EASTLAKE PARADE,KINGSTON ACT 2604,
the Resident,80/13 EASTLAKE PARADE,KINGSTON ACT 2604,
the Resident,79/13 EASTLAKE PARADE,KINGSTON ACT 2604,
the Resident,78/11 EASTLAKE PARADE,KINGSTON ACT 2604,
the Resident,77/11 EASTLAKE PARADE,KINGSTON ACT 2604,
the Resident,76/11 EASTLAKE PARADE,KINGSTON ACT 2604,
the Resident,75/11 EASTLAKE PARADE,KINGSTON ACT 2604,
the Resident,74/11 EASTLAKE PARADE,KINGSTON ACT 2604,
the Resident,73/11 EASTLAKE PARADE,KINGSTON ACT 2604,
the Resident,72/11 EASTLAKE PARADE,KINGSTON ACT 2604,
the Resident,71/11 EASTLAKE PARADE,KINGSTON ACT 2604,
the Resident,70/11 EASTLAKE PARADE,KINGSTON ACT 2604,
the Resident,69/11 EASTLAKE PARADE,KINGSTON ACT 2604,
the Resident,68/11 EASTLAKE PARADE,KINGSTON ACT 2604,
the Resident,67/11 EASTLAKE PARADE,KINGSTON ACT 2604,
the Resident,66/11 EASTLAKE PARADE,KINGSTON ACT 2604,
the Resident,65/11 EASTLAKE PARADE,KINGSTON ACT 2604,
the Resident,64/11 EASTLAKE PARADE,KINGSTON ACT 2604,

the Resident,63/11 EASTLAKE PARADE,KINGSTON ACT 2604,
the Resident,62/11 EASTLAKE PARADE,KINGSTON ACT 2604,
the Resident,61/11 EASTLAKE PARADE,KINGSTON ACT 2604,
the Resident,60/11 EASTLAKE PARADE,KINGSTON ACT 2604,
the Resident,59/11 EASTLAKE PARADE,KINGSTON ACT 2604,
the Resident,58/11 EASTLAKE PARADE,KINGSTON ACT 2604,
the Resident,57/11 EASTLAKE PARADE,KINGSTON ACT 2604,
the Resident,56/11 EASTLAKE PARADE,KINGSTON ACT 2604,
the Resident,55/11 EASTLAKE PARADE,KINGSTON ACT 2604,
the Resident,54/11 EASTLAKE PARADE,KINGSTON ACT 2604,
the Resident,53/11 EASTLAKE PARADE,KINGSTON ACT 2604,
the Resident,52/9 EASTLAKE PARADE,KINGSTON ACT 2604,
the Resident,51/9 EASTLAKE PARADE,KINGSTON ACT 2604,
the Resident,50/9 EASTLAKE PARADE,KINGSTON ACT 2604,
the Resident,49/9 EASTLAKE PARADE,KINGSTON ACT 2604,
the Resident,48/9 EASTLAKE PARADE,KINGSTON ACT 2604,
the Resident,47/9 EASTLAKE PARADE,KINGSTON ACT 2604,
the Resident,46/9 EASTLAKE PARADE,KINGSTON ACT 2604,
the Resident,45/9 EASTLAKE PARADE,KINGSTON ACT 2604,
the Resident,44/9 EASTLAKE PARADE,KINGSTON ACT 2604,
the Resident,43/9 EASTLAKE PARADE,KINGSTON ACT 2604,
the Resident,42/9 EASTLAKE PARADE,KINGSTON ACT 2604,
the Resident,41/9 EASTLAKE PARADE,KINGSTON ACT 2604,
the Resident,40/9 EASTLAKE PARADE,KINGSTON ACT 2604,
the Resident,39/9 EASTLAKE PARADE,KINGSTON ACT 2604,
the Resident,38/9 EASTLAKE PARADE,KINGSTON ACT 2604,
the Resident,37/9 EASTLAKE PARADE,KINGSTON ACT 2604,
the Resident,36/9 EASTLAKE PARADE,KINGSTON ACT 2604,
the Resident,35/9 EASTLAKE PARADE,KINGSTON ACT 2604,
the Resident,34/9 EASTLAKE PARADE,KINGSTON ACT 2604,

the Resident,33/9 EASTLAKE PARADE,KINGSTON ACT 2604,
the Resident,32/9 EASTLAKE PARADE,KINGSTON ACT 2604,
the Resident,31/9 EASTLAKE PARADE,KINGSTON ACT 2604,
the Resident,30/9 EASTLAKE PARADE,KINGSTON ACT 2604,
the Resident,29/9 EASTLAKE PARADE,KINGSTON ACT 2604,
the Resident,28/9 EASTLAKE PARADE,KINGSTON ACT 2604,
the Resident,27/9 EASTLAKE PARADE,KINGSTON ACT 2604,
the Resident,26/7 EASTLAKE PARADE,KINGSTON ACT 2604,
the Resident,25/7 EASTLAKE PARADE,KINGSTON ACT 2604,
the Resident,24/7 EASTLAKE PARADE,KINGSTON ACT 2604,
the Resident,2/7 EASTLAKE PARADE,KINGSTON ACT 2604,
the Resident,19/7 EASTLAKE PARADE,KINGSTON ACT 2604,
the Resident,18/7 EASTLAKE PARADE,KINGSTON ACT 2604,
the Resident,17/7 EASTLAKE PARADE,KINGSTON ACT 2604,
the Resident,16/7 EASTLAKE PARADE,KINGSTON ACT 2604,
the Resident,15/7 EASTLAKE PARADE,KINGSTON ACT 2604,
the Resident,14/7 EASTLAKE PARADE,KINGSTON ACT 2604,
the Resident,13/7 EASTLAKE PARADE,KINGSTON ACT 2604,
the Resident,12/7 EASTLAKE PARADE,KINGSTON ACT 2604,
the Resident,11/7 EASTLAKE PARADE,KINGSTON ACT 2604,
the Resident,104/13 EASTLAKE PARADE,KINGSTON ACT 2604,
the Resident,103/13 EASTLAKE PARADE,KINGSTON ACT 2604,
the Resident,102/13 EASTLAKE PARADE,KINGSTON ACT 2604,
the Resident,101/13 EASTLAKE PARADE,KINGSTON ACT 2604,
the Resident,100/13 EASTLAKE PARADE,KINGSTON ACT 2604,
the Resident,10/7 EASTLAKE PARADE,KINGSTON ACT 2604,
the Resident,1/7 EASTLAKE PARADE,KINGSTON ACT 2604,

4 STANDARD SIGNS FOR MONDAY 28 JULY 2014
KINGSTON
Block 13 Section 49

29 July 2014 to 18 August 2014

Development Application
201425930

11 WENTWORTH AVENUE, KINGSTON

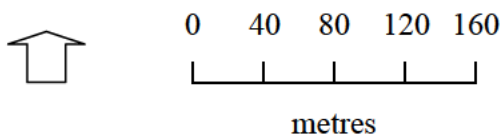
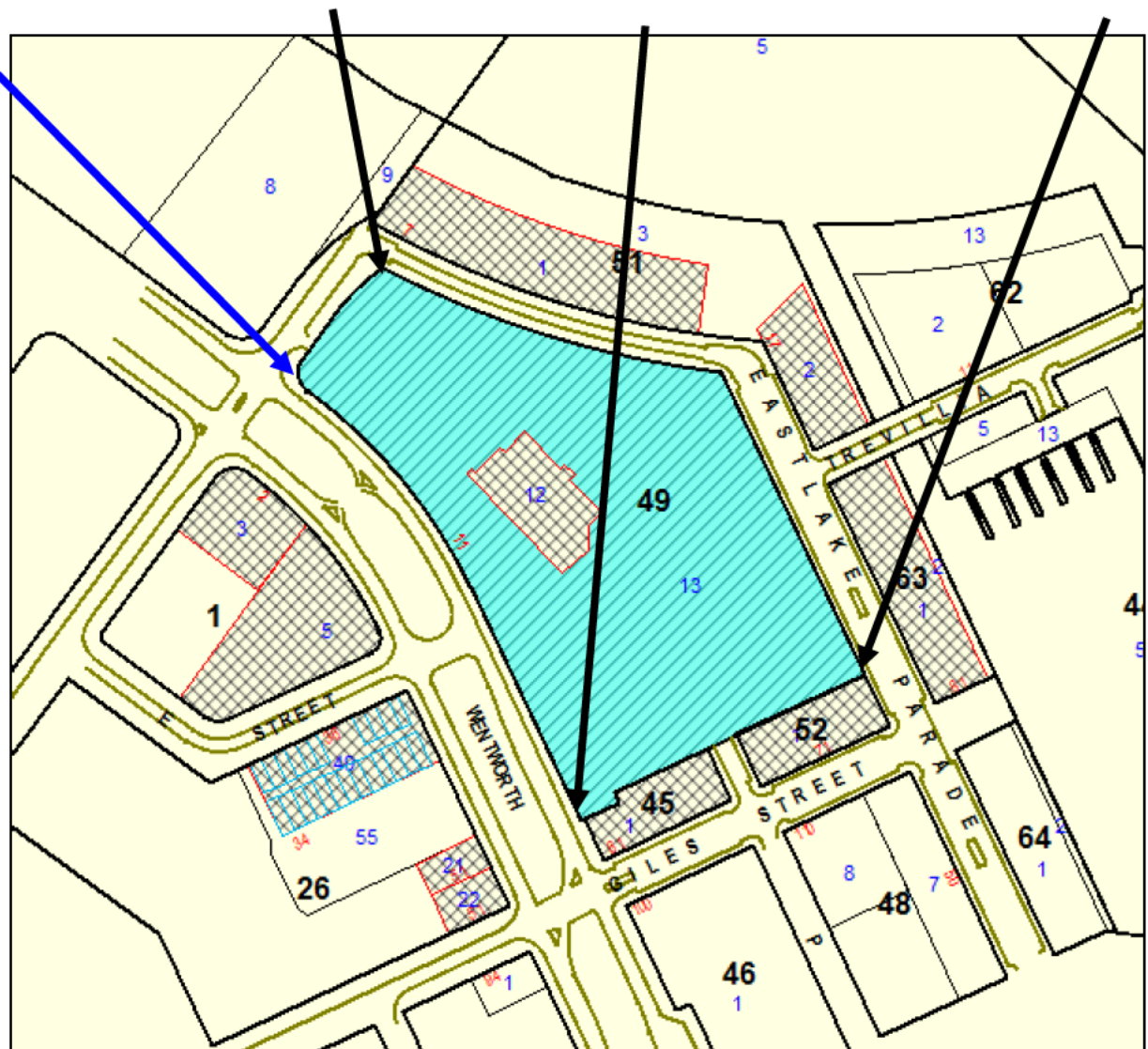

JOB REPORT - Public Notification Generator

JOB DATE: 24 July 2014 3:42 pm

JOB CODE: 153244

OPERATOR: PORTIA MUFUTE

Development Application 201425930

PUBLIC NOTIFICATION

Application lodged on 22 July 2014.

Notification begins on 29 July 2014 and ends on 18 August 2014.

SUBJECT BLOCK

BLOCK: KINGSTON SECTION 49 BLOCK 13
STREET ADDRESS: 11 WENTWORTH AVENUE
LESSEE(S): CLANCY (ACT) PTY LIMITED, DIMOR PTY LTD, MANTEENA PTY LTD,
MEGALO ACCESS ARTS INC, PRO MUSICA INC, PROJECT
COORDINATION (AUSTRALIA) PTY LTD
ADDRESS: 18 NATIONAL CIRCUIT BARTON ACT 2600
APPL_TYPE: SUBC
DEV_DESC: COMMERCIAL. Proposed demolition of the existing switchroom down to
existing slab level.

NEIGHBOURING LESSEES

1. BLOCK: KINGSTON SECTION 51 BLOCK 1 UNIT 1
NAME(S): THE RESIDENT
ADDRESS: 1/7 EASTLAKE PARADE
KINGSTON ACT 2604
2. BLOCK: KINGSTON SECTION 51 BLOCK 1 UNIT 10
NAME(S): THE RESIDENT
ADDRESS: 10/7 EASTLAKE PARADE
KINGSTON ACT 2604
3. BLOCK: KINGSTON SECTION 51 BLOCK 1 UNIT 100
NAME(S): THE RESIDENT
ADDRESS: 100/13 EASTLAKE PARADE

KINGSTON ACT 2604

4. BLOCK: KINGSTON SECTION 51 BLOCK 1 UNIT 101
NAME(S): THE RESIDENT
ADDRESS: 101/13 EASTLAKE PARADE
KINGSTON ACT 2604
5. BLOCK: KINGSTON SECTION 51 BLOCK 1 UNIT 102
NAME(S): THE RESIDENT
ADDRESS: 102/13 EASTLAKE PARADE
KINGSTON ACT 2604
6. BLOCK: KINGSTON SECTION 51 BLOCK 1 UNIT 103
NAME(S): THE RESIDENT
ADDRESS: 103/13 EASTLAKE PARADE
KINGSTON ACT 2604
7. BLOCK: KINGSTON SECTION 51 BLOCK 1 UNIT 104
NAME(S): THE RESIDENT
ADDRESS: 104/13 EASTLAKE PARADE
KINGSTON ACT 2604
8. BLOCK: KINGSTON SECTION 51 BLOCK 1 UNIT 11
NAME(S): THE RESIDENT
ADDRESS: 11/7 EASTLAKE PARADE
KINGSTON ACT 2604
9. BLOCK: KINGSTON SECTION 51 BLOCK 1 UNIT 12
NAME(S): THE RESIDENT
ADDRESS: 12/7 EASTLAKE PARADE
KINGSTON ACT 2604
10. BLOCK: KINGSTON SECTION 51 BLOCK 1 UNIT 13
NAME(S): THE RESIDENT
ADDRESS: 13/7 EASTLAKE PARADE
KINGSTON ACT 2604
11. BLOCK: KINGSTON SECTION 51 BLOCK 1 UNIT 14
NAME(S): THE RESIDENT
ADDRESS: 14/7 EASTLAKE PARADE
KINGSTON ACT 2604
12. BLOCK: KINGSTON SECTION 51 BLOCK 1 UNIT 15
NAME(S): THE RESIDENT
ADDRESS: 15/7 EASTLAKE PARADE
KINGSTON ACT 2604
13. BLOCK: KINGSTON SECTION 51 BLOCK 1 UNIT 16
NAME(S): THE RESIDENT
ADDRESS: 16/7 EASTLAKE PARADE
KINGSTON ACT 2604
14. BLOCK: KINGSTON SECTION 51 BLOCK 1 UNIT 17
NAME(S): THE RESIDENT
ADDRESS: 17/7 EASTLAKE PARADE
KINGSTON ACT 2604
15. BLOCK: KINGSTON SECTION 51 BLOCK 1 UNIT 18
NAME(S): THE RESIDENT
ADDRESS: 18/7 EASTLAKE PARADE

KINGSTON ACT 2604

16. BLOCK: KINGSTON SECTION 51 BLOCK 1 UNIT 19
NAME(S): THE RESIDENT
ADDRESS: 19/7 EASTLAKE PARADE
KINGSTON ACT 2604
17. BLOCK: KINGSTON SECTION 51 BLOCK 1 UNIT 2
NAME(S): THE RESIDENT
ADDRESS: 2/7 EASTLAKE PARADE
KINGSTON ACT 2604
18. BLOCK: KINGSTON SECTION 51 BLOCK 1 UNIT 24
NAME(S): THE RESIDENT
ADDRESS: 24/7 EASTLAKE PARADE
KINGSTON ACT 2604
19. BLOCK: KINGSTON SECTION 51 BLOCK 1 UNIT 25
NAME(S): THE RESIDENT
ADDRESS: 25/7 EASTLAKE PARADE
KINGSTON ACT 2604
20. BLOCK: KINGSTON SECTION 51 BLOCK 1 UNIT 26
NAME(S): THE RESIDENT
ADDRESS: 26/7 EASTLAKE PARADE
KINGSTON ACT 2604
21. BLOCK: KINGSTON SECTION 51 BLOCK 1 UNIT 27
NAME(S): THE RESIDENT
ADDRESS: 27/9 EASTLAKE PARADE
KINGSTON ACT 2604
22. BLOCK: KINGSTON SECTION 51 BLOCK 1 UNIT 28
NAME(S): THE RESIDENT
ADDRESS: 28/9 EASTLAKE PARADE
KINGSTON ACT 2604
23. BLOCK: KINGSTON SECTION 51 BLOCK 1 UNIT 29
NAME(S): THE RESIDENT
ADDRESS: 29/9 EASTLAKE PARADE
KINGSTON ACT 2604
24. BLOCK: KINGSTON SECTION 51 BLOCK 1 UNIT 30
NAME(S): THE RESIDENT
ADDRESS: 30/9 EASTLAKE PARADE
KINGSTON ACT 2604
25. BLOCK: KINGSTON SECTION 51 BLOCK 1 UNIT 31
NAME(S): THE RESIDENT
ADDRESS: 31/9 EASTLAKE PARADE
KINGSTON ACT 2604
26. BLOCK: KINGSTON SECTION 51 BLOCK 1 UNIT 32
NAME(S): THE RESIDENT
ADDRESS: 32/9 EASTLAKE PARADE
KINGSTON ACT 2604
27. BLOCK: KINGSTON SECTION 51 BLOCK 1 UNIT 33
NAME(S): THE RESIDENT
ADDRESS: 33/9 EASTLAKE PARADE

KINGSTON ACT 2604

28. BLOCK: KINGSTON SECTION 51 BLOCK 1 UNIT 34
NAME(S): THE RESIDENT
ADDRESS: 34/9 EASTLAKE PARADE
KINGSTON ACT 2604
29. BLOCK: KINGSTON SECTION 51 BLOCK 1 UNIT 35
NAME(S): THE RESIDENT
ADDRESS: 35/9 EASTLAKE PARADE
KINGSTON ACT 2604
30. BLOCK: KINGSTON SECTION 51 BLOCK 1 UNIT 36
NAME(S): THE RESIDENT
ADDRESS: 36/9 EASTLAKE PARADE
KINGSTON ACT 2604
31. BLOCK: KINGSTON SECTION 51 BLOCK 1 UNIT 37
NAME(S): THE RESIDENT
ADDRESS: 37/9 EASTLAKE PARADE
KINGSTON ACT 2604
32. BLOCK: KINGSTON SECTION 51 BLOCK 1 UNIT 38
NAME(S): THE RESIDENT
ADDRESS: 38/9 EASTLAKE PARADE
KINGSTON ACT 2604
33. BLOCK: KINGSTON SECTION 51 BLOCK 1 UNIT 39
NAME(S): THE RESIDENT
ADDRESS: 39/9 EASTLAKE PARADE
KINGSTON ACT 2604
34. BLOCK: KINGSTON SECTION 51 BLOCK 1 UNIT 40
NAME(S): THE RESIDENT
ADDRESS: 40/9 EASTLAKE PARADE
KINGSTON ACT 2604
35. BLOCK: KINGSTON SECTION 51 BLOCK 1 UNIT 41
NAME(S): THE RESIDENT
ADDRESS: 41/9 EASTLAKE PARADE
KINGSTON ACT 2604
36. BLOCK: KINGSTON SECTION 51 BLOCK 1 UNIT 42
NAME(S): THE RESIDENT
ADDRESS: 42/9 EASTLAKE PARADE
KINGSTON ACT 2604
37. BLOCK: KINGSTON SECTION 51 BLOCK 1 UNIT 43
NAME(S): THE RESIDENT
ADDRESS: 43/9 EASTLAKE PARADE
KINGSTON ACT 2604
38. BLOCK: KINGSTON SECTION 51 BLOCK 1 UNIT 44
NAME(S): THE RESIDENT
ADDRESS: 44/9 EASTLAKE PARADE
KINGSTON ACT 2604
39. BLOCK: KINGSTON SECTION 51 BLOCK 1 UNIT 45
NAME(S): THE RESIDENT
ADDRESS: 45/9 EASTLAKE PARADE

KINGSTON ACT 2604

40. BLOCK: KINGSTON SECTION 51 BLOCK 1 UNIT 46
NAME(S): THE RESIDENT
ADDRESS: 46/9 EASTLAKE PARADE
KINGSTON ACT 2604
41. BLOCK: KINGSTON SECTION 51 BLOCK 1 UNIT 47
NAME(S): THE RESIDENT
ADDRESS: 47/9 EASTLAKE PARADE
KINGSTON ACT 2604
42. BLOCK: KINGSTON SECTION 51 BLOCK 1 UNIT 48
NAME(S): THE RESIDENT
ADDRESS: 48/9 EASTLAKE PARADE
KINGSTON ACT 2604
43. BLOCK: KINGSTON SECTION 51 BLOCK 1 UNIT 49
NAME(S): THE RESIDENT
ADDRESS: 49/9 EASTLAKE PARADE
KINGSTON ACT 2604
44. BLOCK: KINGSTON SECTION 51 BLOCK 1 UNIT 50
NAME(S): THE RESIDENT
ADDRESS: 50/9 EASTLAKE PARADE
KINGSTON ACT 2604
45. BLOCK: KINGSTON SECTION 51 BLOCK 1 UNIT 51
NAME(S): THE RESIDENT
ADDRESS: 51/9 EASTLAKE PARADE
KINGSTON ACT 2604
46. BLOCK: KINGSTON SECTION 51 BLOCK 1 UNIT 52
NAME(S): THE RESIDENT
ADDRESS: 52/9 EASTLAKE PARADE
KINGSTON ACT 2604
47. BLOCK: KINGSTON SECTION 51 BLOCK 1 UNIT 53
NAME(S): THE RESIDENT
ADDRESS: 53/11 EASTLAKE PARADE
KINGSTON ACT 2604
48. BLOCK: KINGSTON SECTION 51 BLOCK 1 UNIT 54
NAME(S): THE RESIDENT
ADDRESS: 54/11 EASTLAKE PARADE
KINGSTON ACT 2604
49. BLOCK: KINGSTON SECTION 51 BLOCK 1 UNIT 55
NAME(S): THE RESIDENT
ADDRESS: 55/11 EASTLAKE PARADE
KINGSTON ACT 2604
50. BLOCK: KINGSTON SECTION 51 BLOCK 1 UNIT 56
NAME(S): THE RESIDENT
ADDRESS: 56/11 EASTLAKE PARADE
KINGSTON ACT 2604
51. BLOCK: KINGSTON SECTION 51 BLOCK 1 UNIT 57
NAME(S): THE RESIDENT
ADDRESS: 57/11 EASTLAKE PARADE

KINGSTON ACT 2604

52. BLOCK: KINGSTON SECTION 51 BLOCK 1 UNIT 58
NAME(S): THE RESIDENT
ADDRESS: 58/11 EASTLAKE PARADE
KINGSTON ACT 2604
53. BLOCK: KINGSTON SECTION 51 BLOCK 1 UNIT 59
NAME(S): THE RESIDENT
ADDRESS: 59/11 EASTLAKE PARADE
KINGSTON ACT 2604
54. BLOCK: KINGSTON SECTION 51 BLOCK 1 UNIT 60
NAME(S): THE RESIDENT
ADDRESS: 60/11 EASTLAKE PARADE
KINGSTON ACT 2604
55. BLOCK: KINGSTON SECTION 51 BLOCK 1 UNIT 61
NAME(S): THE RESIDENT
ADDRESS: 61/11 EASTLAKE PARADE
KINGSTON ACT 2604
56. BLOCK: KINGSTON SECTION 51 BLOCK 1 UNIT 62
NAME(S): THE RESIDENT
ADDRESS: 62/11 EASTLAKE PARADE
KINGSTON ACT 2604
57. BLOCK: KINGSTON SECTION 51 BLOCK 1 UNIT 63
NAME(S): THE RESIDENT
ADDRESS: 63/11 EASTLAKE PARADE
KINGSTON ACT 2604
58. BLOCK: KINGSTON SECTION 51 BLOCK 1 UNIT 64
NAME(S): THE RESIDENT
ADDRESS: 64/11 EASTLAKE PARADE
KINGSTON ACT 2604
59. BLOCK: KINGSTON SECTION 51 BLOCK 1 UNIT 65
NAME(S): THE RESIDENT
ADDRESS: 65/11 EASTLAKE PARADE
KINGSTON ACT 2604
60. BLOCK: KINGSTON SECTION 51 BLOCK 1 UNIT 66
NAME(S): THE RESIDENT
ADDRESS: 66/11 EASTLAKE PARADE
KINGSTON ACT 2604
61. BLOCK: KINGSTON SECTION 51 BLOCK 1 UNIT 67
NAME(S): THE RESIDENT
ADDRESS: 67/11 EASTLAKE PARADE
KINGSTON ACT 2604
62. BLOCK: KINGSTON SECTION 51 BLOCK 1 UNIT 68
NAME(S): THE RESIDENT
ADDRESS: 68/11 EASTLAKE PARADE
KINGSTON ACT 2604
63. BLOCK: KINGSTON SECTION 51 BLOCK 1 UNIT 69
NAME(S): THE RESIDENT
ADDRESS: 69/11 EASTLAKE PARADE

KINGSTON ACT 2604

64. BLOCK: KINGSTON SECTION 51 BLOCK 1 UNIT 70
NAME(S): THE RESIDENT
ADDRESS: 70/11 EASTLAKE PARADE
KINGSTON ACT 2604
65. BLOCK: KINGSTON SECTION 51 BLOCK 1 UNIT 71
NAME(S): THE RESIDENT
ADDRESS: 71/11 EASTLAKE PARADE
KINGSTON ACT 2604
66. BLOCK: KINGSTON SECTION 51 BLOCK 1 UNIT 72
NAME(S): THE RESIDENT
ADDRESS: 72/11 EASTLAKE PARADE
KINGSTON ACT 2604
67. BLOCK: KINGSTON SECTION 51 BLOCK 1 UNIT 73
NAME(S): THE RESIDENT
ADDRESS: 73/11 EASTLAKE PARADE
KINGSTON ACT 2604
68. BLOCK: KINGSTON SECTION 51 BLOCK 1 UNIT 74
NAME(S): THE RESIDENT
ADDRESS: 74/11 EASTLAKE PARADE
KINGSTON ACT 2604
69. BLOCK: KINGSTON SECTION 51 BLOCK 1 UNIT 75
NAME(S): THE RESIDENT
ADDRESS: 75/11 EASTLAKE PARADE
KINGSTON ACT 2604
70. BLOCK: KINGSTON SECTION 51 BLOCK 1 UNIT 76
NAME(S): THE RESIDENT
ADDRESS: 76/11 EASTLAKE PARADE
KINGSTON ACT 2604
71. BLOCK: KINGSTON SECTION 51 BLOCK 1 UNIT 77
NAME(S): THE RESIDENT
ADDRESS: 77/11 EASTLAKE PARADE
KINGSTON ACT 2604
72. BLOCK: KINGSTON SECTION 51 BLOCK 1 UNIT 78
NAME(S): THE RESIDENT
ADDRESS: 78/11 EASTLAKE PARADE
KINGSTON ACT 2604
73. BLOCK: KINGSTON SECTION 51 BLOCK 1 UNIT 79
NAME(S): THE RESIDENT
ADDRESS: 79/13 EASTLAKE PARADE
KINGSTON ACT 2604
74. BLOCK: KINGSTON SECTION 51 BLOCK 1 UNIT 80
NAME(S): THE RESIDENT
ADDRESS: 80/13 EASTLAKE PARADE
KINGSTON ACT 2604
75. BLOCK: KINGSTON SECTION 51 BLOCK 1 UNIT 81
NAME(S): THE RESIDENT
ADDRESS: 81/13 EASTLAKE PARADE

KINGSTON ACT 2604

76. BLOCK: KINGSTON SECTION 51 BLOCK 1 UNIT 82
NAME(S): THE RESIDENT
ADDRESS: 82/13 EASTLAKE PARADE
KINGSTON ACT 2604
77. BLOCK: KINGSTON SECTION 51 BLOCK 1 UNIT 83
NAME(S): THE RESIDENT
ADDRESS: 83/13 EASTLAKE PARADE
KINGSTON ACT 2604
78. BLOCK: KINGSTON SECTION 51 BLOCK 1 UNIT 84
NAME(S): THE RESIDENT
ADDRESS: 84/13 EASTLAKE PARADE
KINGSTON ACT 2604
79. BLOCK: KINGSTON SECTION 51 BLOCK 1 UNIT 85
NAME(S): THE RESIDENT
ADDRESS: 85/13 EASTLAKE PARADE
KINGSTON ACT 2604
80. BLOCK: KINGSTON SECTION 51 BLOCK 1 UNIT 86
NAME(S): THE RESIDENT
ADDRESS: 86/13 EASTLAKE PARADE
KINGSTON ACT 2604
81. BLOCK: KINGSTON SECTION 51 BLOCK 1 UNIT 87
NAME(S): THE RESIDENT
ADDRESS: 87/13 EASTLAKE PARADE
KINGSTON ACT 2604
82. BLOCK: KINGSTON SECTION 51 BLOCK 1 UNIT 88
NAME(S): THE RESIDENT
ADDRESS: 88/13 EASTLAKE PARADE
KINGSTON ACT 2604
83. BLOCK: KINGSTON SECTION 51 BLOCK 1 UNIT 89
NAME(S): THE RESIDENT
ADDRESS: 89/13 EASTLAKE PARADE
KINGSTON ACT 2604
84. BLOCK: KINGSTON SECTION 51 BLOCK 1 UNIT 90
NAME(S): THE RESIDENT
ADDRESS: 90/13 EASTLAKE PARADE
KINGSTON ACT 2604
85. BLOCK: KINGSTON SECTION 51 BLOCK 1 UNIT 91
NAME(S): THE RESIDENT
ADDRESS: 91/13 EASTLAKE PARADE
KINGSTON ACT 2604
86. BLOCK: KINGSTON SECTION 51 BLOCK 1 UNIT 92
NAME(S): THE RESIDENT
ADDRESS: 92/13 EASTLAKE PARADE
KINGSTON ACT 2604
87. BLOCK: KINGSTON SECTION 51 BLOCK 1 UNIT 93
NAME(S): THE RESIDENT
ADDRESS: 93/13 EASTLAKE PARADE

KINGSTON ACT 2604

88. BLOCK: KINGSTON SECTION 51 BLOCK 1 UNIT 94
NAME(S): THE RESIDENT
ADDRESS: 94/13 EASTLAKE PARADE
KINGSTON ACT 2604



89. BLOCK: KINGSTON SECTION 51 BLOCK 1 UNIT 95
NAME(S): THE RESIDENT
ADDRESS: 95/13 EASTLAKE PARADE
KINGSTON ACT 2604



90. BLOCK: KINGSTON SECTION 51 BLOCK 1 UNIT 96
NAME(S): THE RESIDENT
ADDRESS: 96/13 EASTLAKE PARADE
KINGSTON ACT 2604

91. BLOCK: KINGSTON SECTION 51 BLOCK 1 UNIT 97
NAME(S): THE RESIDENT
ADDRESS: 97/13 EASTLAKE PARADE
KINGSTON ACT 2604

92. BLOCK: KINGSTON SECTION 51 BLOCK 1 UNIT 98
NAME(S): THE RESIDENT
ADDRESS: 98/13 EASTLAKE PARADE
KINGSTON ACT 2604

93. BLOCK: KINGSTON SECTION 51 BLOCK 1 UNIT 99
NAME(S): THE RESIDENT
ADDRESS: 99/13 EASTLAKE PARADE
KINGSTON ACT 2604

94. BLOCK: KINGSTON SECTION 51 BLOCK 1 UNIT 104
NAME(S): 
ADDRESS: 

95. BLOCK: KINGSTON SECTION 51 BLOCK 1 UNIT 66
NAME(S): 
ADDRESS: 

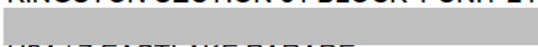
96. BLOCK: KINGSTON SECTION 51 BLOCK 1 UNIT 24
NAME(S): 
ADDRESS: U24 / 7 EASTLAKE PARADE
KINGSTON ACT 2604

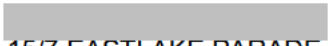
97. BLOCK: KINGSTON SECTION 51 BLOCK 1 UNIT 15
NAME(S): 
ADDRESS: 15/7 EASTLAKE PARADE
KINGSTON ACT 2604

98. BLOCK: KINGSTON SECTION 51 BLOCK 1 UNIT 20
NAME(S): THE RESIDENT
ADDRESS: 20/7 EASTLAKE PARADE
KINGSTON ACT 2604

99. BLOCK: KINGSTON SECTION 51 BLOCK 1 UNIT 21
NAME(S): THE RESIDENT
ADDRESS: 21/7 EASTLAKE PARADE

KINGSTON ACT 2604

100. BLOCK: KINGSTON SECTION 51 BLOCK 1 UNIT 22
NAME(S): THE RESIDENT
ADDRESS: 22/7 EASTLAKE PARADE
KINGSTON ACT 2604
101. BLOCK: KINGSTON SECTION 51 BLOCK 1 UNIT 23
NAME(S): THE RESIDENT
ADDRESS: 23/7 EASTLAKE PARADE
KINGSTON ACT 2604
102. BLOCK: KINGSTON SECTION 51 BLOCK 1 UNIT 103
NAME(S): [REDACTED]
ADDRESS: 103/13 EASTLAKE PARADE
KINGSTON ACT 2604
103. BLOCK: KINGSTON SECTION 51 BLOCK 1 UNIT 69
NAME(S): [REDACTED]
ADDRESS: [REDACTED]
104. BLOCK: KINGSTON SECTION 51 BLOCK 1 UNIT 28
NAME(S): [REDACTED]
ADDRESS: 28/9 EASTLAKE PARADE
KINGSTON ACT 2604
105. BLOCK: KINGSTON SECTION 51 BLOCK 1 UNIT 89
NAME(S): [REDACTED]
ADDRESS: [REDACTED]
106. BLOCK: KINGSTON SECTION 51 BLOCK 1 UNIT 40
NAME(S): [REDACTED]
ADDRESS: 40/9 EASTLAKE PARADE
KINGSTON ACT 2604
107. BLOCK: KINGSTON SECTION 51 BLOCK 1 UNIT 4
NAME(S): [REDACTED]
ADDRESS: [REDACTED]
108. BLOCK: KINGSTON SECTION 51 BLOCK 1 UNIT 6
NAME(S): THE RESIDENT
ADDRESS: 6/7 EASTLAKE PARADE
KINGSTON ACT 2604
109. BLOCK: KINGSTON SECTION 51 BLOCK 1 UNIT 7
NAME(S): THE RESIDENT
ADDRESS: 7/7 EASTLAKE PARADE
KINGSTON ACT 2604
110. BLOCK: KINGSTON SECTION 51 BLOCK 1 UNIT 8
NAME(S): THE RESIDENT
ADDRESS: 8/7 EASTLAKE PARADE
KINGSTON ACT 2604
111. BLOCK: KINGSTON SECTION 51 BLOCK 1 UNIT 44
NAME(S): [REDACTED]
ADDRESS: 44/9 EASTLAKE PARADE

KINGSTON ACT 2604

112. BLOCK: KINGSTON SECTION 51 BLOCK 1 UNIT 73
NAME(S): [REDACTED]
ADDRESS: [REDACTED]

113. BLOCK: KINGSTON SECTION 51 BLOCK 1 UNIT 57
NAME(S): [REDACTED]
ADDRESS: [REDACTED]

114. BLOCK: KINGSTON SECTION 51 BLOCK 1 UNIT 58
NAME(S): [REDACTED]
ADDRESS: 58/11 EASTLAKE PARADE
KINGSTON ACT 2604

115. BLOCK: KINGSTON SECTION 51 BLOCK 1 UNIT 9
NAME(S): [REDACTED]
ADDRESS: [REDACTED]

116. BLOCK: KINGSTON SECTION 51 BLOCK 1 UNIT 9
NAME(S): THE RESIDENT
ADDRESS: 9/7 EASTLAKE PARADE
KINGSTON ACT 2604

117. BLOCK: KINGSTON SECTION 51 BLOCK 1 UNIT 59
NAME(S): [REDACTED]
ADDRESS: [REDACTED]

118. BLOCK: KINGSTON SECTION 51 BLOCK 1 UNIT 90
NAME(S): [REDACTED]
ADDRESS: [REDACTED]

119. BLOCK: KINGSTON SECTION 51 BLOCK 1 UNIT 80
NAME(S): [REDACTED]
ADDRESS: [REDACTED]

120. BLOCK: KINGSTON SECTION 51 BLOCK 1 UNIT 55
NAME(S): [REDACTED]
ADDRESS: 55/11 EASTLAKE PARADE
KINGSTON ACT 2604

121. BLOCK: KINGSTON SECTION 51 BLOCK 1 UNIT 51
NAME(S): [REDACTED]
ADDRESS: [REDACTED]

122. BLOCK: KINGSTON SECTION 51 BLOCK 1 UNIT 83
NAME(S): [REDACTED]
ADDRESS: U83/13 EASTLAKE PARADE
KINGSTON ACT 2604

123. BLOCK: KINGSTON SECTION 51 BLOCK 1 UNIT 38
NAME(S): [REDACTED]
ADDRESS: 38/9 EASTLAKE PARADE

KINGSTON ACT 2604

124. BLOCK: KINGSTON SECTION 51 BLOCK 1 UNIT 66
NAME(S): [REDACTED]
ADDRESS: [REDACTED]

125. BLOCK: KINGSTON SECTION 51 BLOCK 1 UNIT 45
NAME(S): [REDACTED]
ADDRESS: [REDACTED]

126. BLOCK: KINGSTON SECTION 51 BLOCK 1 UNIT 38
NAME(S): [REDACTED]
ADDRESS: 38/9 EASTLAKE PARADE
KINGSTON ACT 2604

127. BLOCK: KINGSTON SECTION 51 BLOCK 1 UNIT 93
NAME(S): [REDACTED]
ADDRESS: 93/13 EASTLAKE PARADE
KINGSTON ACT 2604

128. BLOCK: KINGSTON SECTION 51 BLOCK 1 UNIT 70
NAME(S): [REDACTED]
ADDRESS: [REDACTED]

129. BLOCK: KINGSTON SECTION 51 BLOCK 1 UNIT 81
NAME(S): [REDACTED]
ADDRESS: [REDACTED]

130. BLOCK: KINGSTON SECTION 51 BLOCK 1 UNIT 34
NAME(S): [REDACTED]
ADDRESS: 34/9 EASTLAKE PARADE
KINGSTON ACT 2604

131. BLOCK: KINGSTON SECTION 51 BLOCK 1 UNIT 32
NAME(S): [REDACTED]
ADDRESS: [REDACTED]

132. BLOCK: KINGSTON SECTION 51 BLOCK 1 UNIT 12
NAME(S): [REDACTED]
ADDRESS: 12/7 EASTLAKE PARADE
KINGSTON ACT 2604

133. BLOCK: KINGSTON SECTION 51 BLOCK 1 UNIT 32
NAME(S): [REDACTED]
ADDRESS: [REDACTED]

134. BLOCK: KINGSTON SECTION 51 BLOCK 1 UNIT 64
NAME(S): [REDACTED]
ADDRESS: 64/11 EASTLAKE PARADE
KINGSTON ACT 2604

135. BLOCK: KINGSTON SECTION 51 BLOCK 1 UNIT 26
NAME(S): [REDACTED]
ADDRESS: 26/7 EASTLAKE PARADE

KINGSTON ACT 2604

136. BLOCK: KINGSTON SECTION 51 BLOCK 1 UNIT 30
NAME(S): [REDACTED]
ADDRESS: 30/9 EASTLAKE PARADE
KINGSTON ACT 2604

137. BLOCK: KINGSTON SECTION 51 BLOCK 1 UNIT 54
NAME(S): [REDACTED]
ADDRESS: 54/11 EASTLAKE PARADE
KINGSTON ACT 2604

138. BLOCK: KINGSTON SECTION 51 BLOCK 1 UNIT 95
NAME(S): [REDACTED]
ADDRESS: PO BOX 4589
KINGSTON ACT 2604

139. BLOCK: KINGSTON SECTION 51 BLOCK 1 UNIT 53
NAME(S): [REDACTED]
ADDRESS: 53/11 EASTLAKE PARADE
KINGSTON ACT 2604

140. BLOCK: KINGSTON SECTION 51 BLOCK 1 UNIT 88
NAME(S): [REDACTED]
ADDRESS: U88 13 EASTLAKE PARADE
KINGSTON ACT 2604

141. BLOCK: KINGSTON SECTION 51 BLOCK 1 UNIT 72
NAME(S): [REDACTED]
ADDRESS: 72/11 EASTLAKE PARADE
KINGSTON ACT 2604

142. BLOCK: KINGSTON SECTION 51 BLOCK 1 UNIT 63
NAME(S): [REDACTED]
ADDRESS: 72/11 EASTLAKE PARADE
KINGSTON ACT 2604

143. BLOCK: KINGSTON SECTION 51 BLOCK 1 UNIT 35
NAME(S): [REDACTED]
ADDRESS: [REDACTED]

144. BLOCK: KINGSTON SECTION 51 BLOCK 1 UNIT 42
NAME(S): [REDACTED]
ADDRESS: [REDACTED]

145. BLOCK: KINGSTON SECTION 51 BLOCK 1 UNIT 31
NAME(S): [REDACTED]
ADDRESS: [REDACTED]

146. BLOCK: KINGSTON SECTION 51 BLOCK 1 UNIT 94
NAME(S): [REDACTED]
ADDRESS: [REDACTED]

147. BLOCK: KINGSTON SECTION 51 BLOCK 1 UNIT 23
NAME(S): [REDACTED]
ADDRESS: 23/7 EASTLAKE PARADE

KINGSTON ACT 2604

148. BLOCK: KINGSTON SECTION 51 BLOCK 1 UNIT 48
NAME(S): [REDACTED]
ADDRESS: [REDACTED]

149. BLOCK: KINGSTON SECTION 51 BLOCK 1 UNIT 92
NAME(S): [REDACTED]
ADDRESS: [REDACTED]

150. BLOCK: KINGSTON SECTION 51 BLOCK 1 UNIT 18
NAME(S): [REDACTED]
ADDRESS: [REDACTED]

151. BLOCK: KINGSTON SECTION 51 BLOCK 1 UNIT 21
NAME(S): [REDACTED]
ADDRESS: 21/7 EASTLAKE PARADE
KINGSTON ACT 2604

152. BLOCK: KINGSTON SECTION 51 BLOCK 1 UNIT 100
NAME(S): [REDACTED]
ADDRESS: [REDACTED]

153. BLOCK: KINGSTON SECTION 51 BLOCK 1 UNIT 22
NAME(S): [REDACTED]
ADDRESS: 22/7 EASTLAKE PARADE
KINGSTON ACT 2604

154. BLOCK: KINGSTON SECTION 51 BLOCK 1 UNIT 52
NAME(S): [REDACTED]
ADDRESS: [REDACTED]

155. BLOCK: KINGSTON SECTION 51 BLOCK 1 UNIT 60
NAME(S): [REDACTED]
ADDRESS: 60/11 EASTLAKE PARADE
KINGSTON ACT 2604

156. BLOCK: KINGSTON SECTION 51 BLOCK 1 UNIT 7
NAME(S): [REDACTED]
ADDRESS: [REDACTED]

157. BLOCK: KINGSTON SECTION 51 BLOCK 1 UNIT 46
NAME(S): [REDACTED]
ADDRESS: [REDACTED]

158. BLOCK: KINGSTON SECTION 51 BLOCK 1 UNIT 20
NAME(S): [REDACTED]
ADDRESS: 20/7 EASTLAKE PARADE
KINGSTON ACT 2604

159. BLOCK: KINGSTON SECTION 51 BLOCK 1 UNIT 33
NAME(S): [REDACTED]
ADDRESS: 33/9 EASTLAKE PARADE

KINGSTON ACT 2604

160. BLOCK: KINGSTON SECTION 51 BLOCK 1 UNIT 84
NAME(S): [REDACTED]
ADDRESS: [REDACTED]

161. BLOCK: KINGSTON SECTION 51 BLOCK 1 UNIT 76
NAME(S): [REDACTED]
ADDRESS: 76/11 EASTLAKE PARADE
KINGSTON ACT 2604

162. BLOCK: KINGSTON SECTION 51 BLOCK 1 UNIT 68
NAME(S): [REDACTED]
ADDRESS: [REDACTED]

163. BLOCK: KINGSTON SECTION 51 BLOCK 1 UNIT 98
NAME(S): [REDACTED]
ADDRESS: 98/13 EASTLAKE PARADE
KINGSTON ACT 2604

164. BLOCK: KINGSTON SECTION 51 BLOCK 1 UNIT 92
NAME(S): [REDACTED]
ADDRESS: [REDACTED]

165. BLOCK: KINGSTON SECTION 51 BLOCK 1 UNIT 39
NAME(S): [REDACTED]
ADDRESS: 39/9 EASTLAKE PARADE
KINGSTON ACT 2604

166. BLOCK: KINGSTON SECTION 51 BLOCK 1 UNIT 87
NAME(S): [REDACTED]
ADDRESS: 87/13 EASTLAKE PARADE
KINGSTON ACT 2604

167. BLOCK: KINGSTON SECTION 51 BLOCK 1 UNIT 97
NAME(S): [REDACTED]
ADDRESS: [REDACTED]

168. BLOCK: KINGSTON SECTION 51 BLOCK 1 UNIT 31
NAME(S): [REDACTED]
ADDRESS: [REDACTED]

169. BLOCK: KINGSTON SECTION 51 BLOCK 1 UNIT 34
NAME(S): [REDACTED]
ADDRESS: 34/9 EASTLAKE PARADE
KINGSTON ACT 2604

170. BLOCK: KINGSTON SECTION 51 BLOCK 1 UNIT 49
NAME(S): [REDACTED]
ADDRESS: 49/9 EASTLAKE PARADE
KINGSTON ACT 2604

171. BLOCK: KINGSTON SECTION 51 BLOCK 1 UNIT 16
NAME(S): [REDACTED]
ADDRESS: 16/7 EASTLAKE PARADE

KINGSTON ACT 2604

172. BLOCK: KINGSTON SECTION 51 BLOCK 1 UNIT 33
NAME(S): [REDACTED]
ADDRESS: 33/9 EASTLAKE PARADE
KINGSTON ACT 2604

173. BLOCK: KINGSTON SECTION 51 BLOCK 1 UNIT 46
NAME(S): [REDACTED]
ADDRESS: [REDACTED]

174. BLOCK: KINGSTON SECTION 51 BLOCK 1 UNIT 77
NAME(S): [REDACTED]
ADDRESS: [REDACTED]

175. BLOCK: KINGSTON SECTION 51 BLOCK 1 UNIT 86
NAME(S): [REDACTED]
ADDRESS: [REDACTED]

176. BLOCK: KINGSTON SECTION 51 BLOCK 1 UNIT 14
NAME(S): [REDACTED]
ADDRESS: [REDACTED]

177. BLOCK: KINGSTON SECTION 51 BLOCK 1 UNIT 19
NAME(S): [REDACTED]
ADDRESS: [REDACTED]

178. BLOCK: KINGSTON SECTION 51 BLOCK 1 UNIT 6
NAME(S): [REDACTED]
ADDRESS: [REDACTED]

179. BLOCK: KINGSTON SECTION 51 BLOCK 1 UNIT 8
NAME(S): [REDACTED]
ADDRESS: [REDACTED]

180. BLOCK: KINGSTON SECTION 51 BLOCK 1 UNIT 3
NAME(S): [REDACTED]
ADDRESS: 3/7 EASTLAKE PARADE
KINGSTON ACT 2604

181. BLOCK: KINGSTON SECTION 51 BLOCK 1 UNIT 4
NAME(S): THE RESIDENT
ADDRESS: 4/7 EASTLAKE PARADE
KINGSTON ACT 2604

182. BLOCK: KINGSTON SECTION 51 BLOCK 1 UNIT 5
NAME(S): THE RESIDENT
ADDRESS: 5/7 EASTLAKE PARADE
KINGSTON ACT 2604

183. BLOCK: KINGSTON SECTION 51 BLOCK 1 UNIT 13
NAME(S): [REDACTED]
ADDRESS: [REDACTED]

[REDACTED]
184. BLOCK: KINGSTON SECTION 51 BLOCK 1 UNIT 56
NAME(S): [REDACTED]
ADDRESS: [REDACTED]

185. BLOCK: KINGSTON SECTION 51 BLOCK 1 UNIT 49
NAME(S): [REDACTED]
ADDRESS: 49/9 EASTLAKE PARADE
KINGSTON ACT 2604

186. BLOCK: KINGSTON SECTION 51 BLOCK 1 UNIT 1
NAME(S): [REDACTED]
ADDRESS: [REDACTED]

187. BLOCK: KINGSTON SECTION 51 BLOCK 1 UNIT 91
NAME(S): [REDACTED]
ADDRESS: 91/13 EASTLAKE PARADE
KINGSTON ACT 2604

188. BLOCK: KINGSTON SECTION 51 BLOCK 1 UNIT 61
NAME(S): [REDACTED]
ADDRESS: [REDACTED]

189. BLOCK: KINGSTON SECTION 51 BLOCK 1 UNIT 18
NAME(S): [REDACTED]
ADDRESS: [REDACTED]

190. BLOCK: KINGSTON SECTION 51 BLOCK 1 UNIT 67
NAME(S): [REDACTED]
ADDRESS: [REDACTED]

191. BLOCK: KINGSTON SECTION 51 BLOCK 1 UNIT 37
NAME(S): [REDACTED]
ADDRESS: [REDACTED]

192. BLOCK: KINGSTON SECTION 51 BLOCK 1 UNIT 27
NAME(S): [REDACTED]
ADDRESS: 27/9 EASTLAKE PARADE
KINGSTON ACT 2604

193. BLOCK: KINGSTON SECTION 51 BLOCK 1 UNIT 67
NAME(S): [REDACTED]
ADDRESS: [REDACTED]

194. BLOCK: KINGSTON SECTION 51 BLOCK 1 UNIT 39
NAME(S): [REDACTED]
ADDRESS: 39/9 EASTLAKE PARADE
KINGSTON ACT 2604

195. BLOCK: KINGSTON SECTION 51 BLOCK 1 UNIT 15
NAME(S): [REDACTED]
ADDRESS: 15/7 EASTLAKE PARADE

KINGSTON ACT 2604

196. BLOCK: KINGSTON SECTION 51 BLOCK 1 UNIT 96
NAME(S): [REDACTED]
ADDRESS: [REDACTED]

197. BLOCK: KINGSTON SECTION 51 BLOCK 1 UNIT 2
NAME(S): [REDACTED]
ADDRESS: [REDACTED]

198. BLOCK: KINGSTON SECTION 51 BLOCK 1 UNIT 73
NAME(S): [REDACTED]
ADDRESS: [REDACTED]

199. BLOCK: KINGSTON SECTION 51 BLOCK 1 UNIT 17
NAME(S): [REDACTED]
ADDRESS: [REDACTED]

200. BLOCK: KINGSTON SECTION 51 BLOCK 1 UNIT 82
NAME(S): [REDACTED]
ADDRESS: [REDACTED]

201. BLOCK: KINGSTON SECTION 51 BLOCK 1 UNIT 102
NAME(S): [REDACTED]
ADDRESS: 102/13 EASTLAKE PARADE
KINGSTON ACT 2604

202. BLOCK: KINGSTON SECTION 51 BLOCK 1 UNIT 74
NAME(S): [REDACTED]
ADDRESS: [REDACTED]

203. BLOCK: KINGSTON SECTION 51 BLOCK 1 UNIT 47
NAME(S): [REDACTED]
ADDRESS: 47/9 EASTLAKE PARADE
KINGSTON ACT 2604

204. BLOCK: KINGSTON SECTION 51 BLOCK 1 UNIT 25
NAME(S): [REDACTED]
ADDRESS: [REDACTED]

205. BLOCK: KINGSTON SECTION 51 BLOCK 1 UNIT 85
NAME(S): [REDACTED]
ADDRESS: 85/13 EASTLAKE PARADE
KINGSTON ACT 2604

206. BLOCK: KINGSTON SECTION 51 BLOCK 1 UNIT 101
NAME(S): [REDACTED]
ADDRESS: [REDACTED]

207. BLOCK: KINGSTON SECTION 51 BLOCK 1 UNIT 10
NAME(S): [REDACTED]
ADDRESS: [REDACTED]

[REDACTED]

208. BLOCK: KINGSTON SECTION 51 BLOCK 1 UNIT 71
NAME(S): [REDACTED]
ADDRESS: 71/11 EASTLAKE PARADE
KINGSTON ACT 2604

209. BLOCK: KINGSTON SECTION 51 BLOCK 1 UNIT 65
NAME(S): [REDACTED]
ADDRESS: [REDACTED]

210. BLOCK: KINGSTON SECTION 51 BLOCK 1 UNIT 69
NAME(S): [REDACTED]
ADDRESS: [REDACTED]

211. BLOCK: KINGSTON SECTION 51 BLOCK 1 UNIT 37
NAME(S): THE OWNERS-UNITS PLAN NO 3107
ADDRESS: 37/9 EASTLAKE PARADE
KINGSTON ACT 2604

212. BLOCK: KINGSTON SECTION 51 BLOCK 1 UNIT 1
NAME(S): [REDACTED]
ADDRESS: [REDACTED]

213. BLOCK: KINGSTON SECTION 51 BLOCK 1 UNIT 43
NAME(S): [REDACTED]
ADDRESS: 43/9 EASTLAKE PARADE
KINGSTON ACT 2604

214. BLOCK: KINGSTON SECTION 51 BLOCK 1 UNIT 78
NAME(S): [REDACTED]
ADDRESS: [REDACTED]

215. BLOCK: KINGSTON SECTION 51 BLOCK 1 UNIT 36
NAME(S): [REDACTED]
ADDRESS: 36/9 EASTLAKE PARADE
KINGSTON ACT 2604

216. BLOCK: KINGSTON SECTION 51 BLOCK 1 UNIT 5
NAME(S): [REDACTED]
ADDRESS: 5/7 EASTLAKE PARADE
KINGSTON ACT 2604

217. BLOCK: KINGSTON SECTION 51 BLOCK 1 UNIT 75
NAME(S): [REDACTED]
ADDRESS: [REDACTED]

218. BLOCK: KINGSTON SECTION 51 BLOCK 1 UNIT 50
NAME(S): [REDACTED]
ADDRESS: [REDACTED]

219. BLOCK: KINGSTON SECTION 51 BLOCK 1 UNIT 99
NAME(S): [REDACTED]
ADDRESS: [REDACTED]

- [REDACTED]
220. BLOCK: KINGSTON SECTION 51 BLOCK 1 UNIT 41
NAME(S): [REDACTED]
ADDRESS: [REDACTED]
221. BLOCK: KINGSTON SECTION 51 BLOCK 1 UNIT 29
NAME(S): [REDACTED]
ADDRESS: 29/9 EASTLAKE PARADE
KINGSTON ACT 2604
222. BLOCK: KINGSTON SECTION 51 BLOCK 1 UNIT 79
NAME(S): [REDACTED]
ADDRESS: 79/13 EASTLAKE PARADE
KINGSTON ACT 2604
223. BLOCK: KINGSTON SECTION 51 BLOCK 1 UNIT 11
NAME(S): [REDACTED]
ADDRESS: 11/7 EASTLAKE PARADE
KINGSTON ACT
224. BLOCK: KINGSTON SECTION 51 BLOCK 1 UNIT 62
NAME(S): [REDACTED]
ADDRESS: [REDACTED]
225. BLOCK: KINGSTON SECTION 51 BLOCK 1 UNIT 94
NAME(S): [REDACTED]
ADDRESS: [REDACTED]
226. BLOCK: KINGSTON SECTION 51 BLOCK 2
NAME(S): THE RESIDENT
ADDRESS: EASTLAKE PARADE
KINGSTON ACT 2604
227. BLOCK: KINGSTON SECTION 51 BLOCK 2
NAME(S): [REDACTED]
ADDRESS: [REDACTED]
228. BLOCK: KINGSTON SECTION 63 BLOCK 1
NAME(S): [REDACTED]
ADDRESS: [REDACTED]
229. BLOCK: KINGSTON SECTION 63 BLOCK 1
NAME(S): THE RESIDENT
ADDRESS: 81 GILES STREET
KINGSTON ACT 2604
230. BLOCK: KINGSTON SECTION 1 BLOCK 3
NAME(S): THE GREEK ORTHODOX COMMUNITY AND CHURCH OF CANBERRA
AND DISTRICT INCORPORATED
ADDRESS: 1 GOSSE STREET
KINGSTON ACT 2604
231. BLOCK: KINGSTON SECTION 1 BLOCK 3
NAME(S): THE RESIDENT

ADDRESS: 2 WENTWORTH AVENUE
KINGSTON ACT 2604

232. BLOCK: KINGSTON SECTION 1 BLOCK 5
NAME(S): THE RESIDENT
ADDRESS: 1 GOSSE STREET
KINGSTON ACT 2604

233. BLOCK: KINGSTON SECTION 1 BLOCK 5
NAME(S): GREEK ORTHODOX COMMUNITY AND CHURCH OF CANBERRA AND
DISTRICT INCORPORATED
ADDRESS: GPO BOX 208
CANBERRA ACT 2601

234. BLOCK: KINGSTON SECTION 26 BLOCK 49 UNIT 1
NAME(S): THE RESIDENT
ADDRESS: 1/36 GOSSE STREET
KINGSTON ACT 2604

235. BLOCK: KINGSTON SECTION 26 BLOCK 49 UNIT 10
NAME(S): THE RESIDENT
ADDRESS: 10/36 GOSSE STREET
KINGSTON ACT 2604

236. BLOCK: KINGSTON SECTION 26 BLOCK 49 UNIT 11
NAME(S): THE RESIDENT
ADDRESS: 11/36 GOSSE STREET
KINGSTON ACT 2604

237. BLOCK: KINGSTON SECTION 26 BLOCK 49 UNIT 12
NAME(S): THE RESIDENT
ADDRESS: 12/36 GOSSE STREET
KINGSTON ACT 2604

238. BLOCK: KINGSTON SECTION 26 BLOCK 49 UNIT 13
NAME(S): THE RESIDENT
ADDRESS: 13/36 GOSSE STREET
KINGSTON ACT 2604

239. BLOCK: KINGSTON SECTION 26 BLOCK 49 UNIT 14
NAME(S): THE RESIDENT
ADDRESS: 14/36 GOSSE STREET
KINGSTON ACT 2604

240. BLOCK: KINGSTON SECTION 26 BLOCK 49 UNIT 15
NAME(S): THE RESIDENT
ADDRESS: 15/36 GOSSE STREET
KINGSTON ACT 2604

241. BLOCK: KINGSTON SECTION 26 BLOCK 49 UNIT 16
NAME(S): THE RESIDENT
ADDRESS: 16/36 GOSSE STREET
KINGSTON ACT 2604

242. BLOCK: KINGSTON SECTION 26 BLOCK 49 UNIT 17
NAME(S): THE RESIDENT
ADDRESS: 17/36 GOSSE STREET
KINGSTON ACT 2604

243. BLOCK: KINGSTON SECTION 26 BLOCK 49 UNIT 18

NAME(S): THE RESIDENT
ADDRESS: 18/36 GOSSE STREET
KINGSTON ACT 2604

244. BLOCK: KINGSTON SECTION 26 BLOCK 49 UNIT 19
NAME(S): THE RESIDENT
ADDRESS: 19/36 GOSSE STREET
KINGSTON ACT 2604

245. BLOCK: KINGSTON SECTION 26 BLOCK 49 UNIT 2
NAME(S): THE RESIDENT
ADDRESS: 2/36 GOSSE STREET
KINGSTON ACT 2604

246. BLOCK: KINGSTON SECTION 26 BLOCK 49 UNIT 20
NAME(S): THE RESIDENT
ADDRESS: 20/36 GOSSE STREET
KINGSTON ACT 2604

247. BLOCK: KINGSTON SECTION 26 BLOCK 49 UNIT 21
NAME(S): THE RESIDENT
ADDRESS: 21/36 GOSSE STREET
KINGSTON ACT 2604

248. BLOCK: KINGSTON SECTION 26 BLOCK 49 UNIT 22
NAME(S): THE RESIDENT
ADDRESS: 22/36 GOSSE STREET
KINGSTON ACT 2604

249. BLOCK: KINGSTON SECTION 26 BLOCK 49 UNIT 23
NAME(S): THE RESIDENT
ADDRESS: 23/36 GOSSE STREET
KINGSTON ACT 2604

250. BLOCK: KINGSTON SECTION 26 BLOCK 49 UNIT 3
NAME(S): THE RESIDENT
ADDRESS: 3/36 GOSSE STREET
KINGSTON ACT 2604

251. BLOCK: KINGSTON SECTION 26 BLOCK 49
NAME(S): THE RESIDENT
ADDRESS: 36 GOSSE STREET
KINGSTON ACT 2604

252. BLOCK: KINGSTON SECTION 26 BLOCK 49 UNIT 4
NAME(S): THE RESIDENT
ADDRESS: 4/36 GOSSE STREET
KINGSTON ACT 2604

253. BLOCK: KINGSTON SECTION 26 BLOCK 49 UNIT 5
NAME(S): THE RESIDENT
ADDRESS: 5/36 GOSSE STREET
KINGSTON ACT 2604

254. BLOCK: KINGSTON SECTION 26 BLOCK 49 UNIT 6
NAME(S): THE RESIDENT
ADDRESS: 6/36 GOSSE STREET
KINGSTON ACT 2604

255. BLOCK: KINGSTON SECTION 26 BLOCK 49 UNIT 7

NAME(S): THE RESIDENT
ADDRESS: 7/36 GOSSE STREET
KINGSTON ACT 2604

256. BLOCK: KINGSTON SECTION 26 BLOCK 49 UNIT 17
NAME(S): [REDACTED]
ADDRESS: [REDACTED]

257. BLOCK: KINGSTON SECTION 26 BLOCK 49 UNIT 8
NAME(S): [REDACTED]
ADDRESS: 8/36 GOSSE STREET
KINGSTON ACT 2604

258. BLOCK: KINGSTON SECTION 26 BLOCK 49 UNIT 9
NAME(S): THE RESIDENT
ADDRESS: 9/36 GOSSE STREET
KINGSTON ACT 2604

259. BLOCK: KINGSTON SECTION 26 BLOCK 49 UNIT 10
NAME(S): [REDACTED]
ADDRESS: [REDACTED]

260. BLOCK: KINGSTON SECTION 26 BLOCK 49 UNIT 4
NAME(S): [REDACTED]
ADDRESS: [REDACTED]

261. BLOCK: KINGSTON SECTION 26 BLOCK 49 UNIT 22
NAME(S): [REDACTED]
ADDRESS: [REDACTED]

262. BLOCK: KINGSTON SECTION 26 BLOCK 49 UNIT 11
NAME(S): [REDACTED]
ADDRESS: [REDACTED]

263. BLOCK: KINGSTON SECTION 26 BLOCK 49 UNIT 19
NAME(S): [REDACTED]
ADDRESS: [REDACTED]

264. BLOCK: KINGSTON SECTION 26 BLOCK 49 UNIT 5
NAME(S): [REDACTED]
ADDRESS: 5/36 GOSSE STREET
KINGSTON ACT 2604

265. BLOCK: KINGSTON SECTION 26 BLOCK 49 UNIT 9
NAME(S): [REDACTED]
ADDRESS: 9/36 GOSSE STREET
KINGSTON ACT 2604

266. BLOCK: KINGSTON SECTION 26 BLOCK 49 UNIT 19
NAME(S): [REDACTED]
ADDRESS: [REDACTED]

267. BLOCK: KINGSTON SECTION 26 BLOCK 49 UNIT 23

NAME(S): [REDACTED]
ADDRESS: [REDACTED]

268. BLOCK: KINGSTON SECTION 26 BLOCK 49 UNIT 15
NAME(S): [REDACTED]
ADDRESS: 15/36 GOSSE STREET
KINGSTON ACT 2604

269. BLOCK: KINGSTON SECTION 26 BLOCK 49 UNIT 16
NAME(S): [REDACTED]
ADDRESS: [REDACTED]

270. BLOCK: KINGSTON SECTION 26 BLOCK 49 UNIT 20
NAME(S): [REDACTED]
ADDRESS: 20/36 GOSSE STREET
KINGSTON ACT 2604

271. BLOCK: KINGSTON SECTION 26 BLOCK 49 UNIT 7
NAME(S): [REDACTED]
ADDRESS: U7/36 GOSSE STREET
KINGSTON ACT 2604

272. BLOCK: KINGSTON SECTION 26 BLOCK 49 UNIT 1
NAME(S): [REDACTED]
ADDRESS: [REDACTED]

273. BLOCK: KINGSTON SECTION 26 BLOCK 49 UNIT 18
NAME(S): [REDACTED]
ADDRESS: [REDACTED]

274. BLOCK: KINGSTON SECTION 26 BLOCK 49 UNIT 12
NAME(S): [REDACTED]
ADDRESS: 12/36 GOSSE STREET
KINGSTON ACT 2604

275. BLOCK: KINGSTON SECTION 26 BLOCK 49 UNIT 1
NAME(S): [REDACTED]
ADDRESS: [REDACTED]

276. BLOCK: KINGSTON SECTION 26 BLOCK 49 UNIT 21
NAME(S): [REDACTED]
ADDRESS: 21/36 GOSSE STREET
KINGSTON ACT 2604

277. BLOCK: KINGSTON SECTION 26 BLOCK 49 UNIT 15
NAME(S): [REDACTED]
ADDRESS: 15/36 GOSSE STREET
KINGSTON ACT 2604

278. BLOCK: KINGSTON SECTION 26 BLOCK 49 UNIT 20
NAME(S): [REDACTED]
ADDRESS: 20/36 GOSSE STREET
KINGSTON ACT 2604

279. BLOCK: KINGSTON SECTION 26 BLOCK 49 UNIT 3

NAME(S): [REDACTED]
ADDRESS: [REDACTED]

280. BLOCK: KINGSTON SECTION 26 BLOCK 49 UNIT 6
NAME(S): [REDACTED]
ADDRESS: 6/36 GOSSE STREET
KINGSTON ACT 2604

281. BLOCK: KINGSTON SECTION 26 BLOCK 49 UNIT 14
NAME(S): [REDACTED]
ADDRESS: [REDACTED]

282. BLOCK: KINGSTON SECTION 26 BLOCK 49 UNIT 7
NAME(S): [REDACTED]
ADDRESS: U7/36 GOSSE STREET
KINGSTON ACT 2604

283. BLOCK: KINGSTON SECTION 26 BLOCK 49 UNIT 2
NAME(S): [REDACTED]
ADDRESS: [REDACTED]

284. BLOCK: KINGSTON SECTION 26 BLOCK 49
NAME(S): [REDACTED]
ADDRESS: [REDACTED]

285. BLOCK: KINGSTON SECTION 26 BLOCK 49 UNIT 13
NAME(S): [REDACTED]
ADDRESS: 13/36 GOSSE STREET
KINGSTON ACT 2604

286. BLOCK: KINGSTON SECTION 26 BLOCK 21 UNIT 1
NAME(S): THE RESIDENT
ADDRESS: 1/43 GILES STREET
KINGSTON ACT 2604

287. BLOCK: KINGSTON SECTION 26 BLOCK 21 UNIT 10
NAME(S): THE RESIDENT
ADDRESS: 10/43-51 GILES STREET
KINGSTON ACT 2604

288. BLOCK: KINGSTON SECTION 26 BLOCK 21 UNIT 11
NAME(S): THE RESIDENT
ADDRESS: 11/41-53 GILES STREET
KINGSTON ACT 2604

289. BLOCK: KINGSTON SECTION 26 BLOCK 21 UNIT 12
NAME(S): THE RESIDENT
ADDRESS: 12/41-53 GILES STREET
KINGSTON ACT 2604

290. BLOCK: KINGSTON SECTION 26 BLOCK 21 UNIT 13
NAME(S): THE RESIDENT
ADDRESS: 13/43-51 GILES STREET
KINGSTON ACT 2604

291. BLOCK: KINGSTON SECTION 26 BLOCK 21 UNIT 14

NAME(S): THE RESIDENT
ADDRESS: 14/41-53 GILES STREET
KINGSTON ACT 2604

292. BLOCK: KINGSTON SECTION 26 BLOCK 21 UNIT 15
NAME(S): THE RESIDENT
ADDRESS: 15/43-51 GILES STREET
KINGSTON ACT 2604

293. BLOCK: KINGSTON SECTION 26 BLOCK 21 UNIT 16
NAME(S): THE RESIDENT
ADDRESS: 16/41-53 GILES STREET
KINGSTON ACT 2604

294. BLOCK: KINGSTON SECTION 26 BLOCK 21 UNIT 17
NAME(S): THE RESIDENT
ADDRESS: 17/43-51 GILES STREET
KINGSTON ACT 2604

295. BLOCK: KINGSTON SECTION 26 BLOCK 21 UNIT 18
NAME(S): THE RESIDENT
ADDRESS: 18/41-53 GILES STREET
KINGSTON ACT 2604

296. BLOCK: KINGSTON SECTION 26 BLOCK 21 UNIT 19
NAME(S): THE RESIDENT
ADDRESS: 19/41-53 GILES STREET
KINGSTON ACT 2604

297. BLOCK: KINGSTON SECTION 26 BLOCK 21 UNIT 2
NAME(S): THE RESIDENT
ADDRESS: 2/43-51 GILES STREET
KINGSTON ACT 2604

298. BLOCK: KINGSTON SECTION 26 BLOCK 21 UNIT 20
NAME(S): THE RESIDENT
ADDRESS: 20/41-53 GILES STREET
KINGSTON ACT 2604

299. BLOCK: KINGSTON SECTION 26 BLOCK 21 UNIT 21
NAME(S): THE RESIDENT
ADDRESS: 21/41-53 GILES STREET
KINGSTON ACT 2604

300. BLOCK: KINGSTON SECTION 26 BLOCK 21 UNIT 22
NAME(S): THE RESIDENT
ADDRESS: 22/43-51 GILES STREET
KINGSTON ACT 2604

301. BLOCK: KINGSTON SECTION 26 BLOCK 21 UNIT 23
NAME(S): THE RESIDENT
ADDRESS: 23/43 GILES STREET
KINGSTON ACT 2604

302. BLOCK: KINGSTON SECTION 26 BLOCK 21 UNIT 24
NAME(S): THE RESIDENT
ADDRESS: 24/43-51 GILES STREET
KINGSTON ACT 2604

303. BLOCK: KINGSTON SECTION 26 BLOCK 21 UNIT 25

NAME(S): THE RESIDENT
ADDRESS: 25/43 GILES STREET
KINGSTON ACT 2604

304. BLOCK: KINGSTON SECTION 26 BLOCK 21 UNIT 26
NAME(S): THE RESIDENT
ADDRESS: 26/43-51 GILES STREET
KINGSTON ACT 2604

305. BLOCK: KINGSTON SECTION 26 BLOCK 21 UNIT 27
NAME(S): THE RESIDENT
ADDRESS: 27/43-51 GILES STREET
KINGSTON ACT 2604

306. BLOCK: KINGSTON SECTION 26 BLOCK 21 UNIT 28
NAME(S): THE RESIDENT
ADDRESS: 28/43-51 GILES STREET
KINGSTON ACT 2604

307. BLOCK: KINGSTON SECTION 26 BLOCK 21 UNIT 29
NAME(S): THE RESIDENT
ADDRESS: 29/43-51 GILES STREET
KINGSTON ACT 2604

308. BLOCK: KINGSTON SECTION 26 BLOCK 21 UNIT 30
NAME(S): THE RESIDENT
ADDRESS: 30/43-51 GILES STREET
KINGSTON ACT 2604

309. BLOCK: KINGSTON SECTION 26 BLOCK 21 UNIT 31
NAME(S): THE RESIDENT
ADDRESS: 31/43-51 GILES STREET
KINGSTON ACT 2604

310. BLOCK: KINGSTON SECTION 26 BLOCK 21 UNIT 32
NAME(S): THE RESIDENT
ADDRESS: 32/43-51 GILES STREET
KINGSTON ACT 2604

311. BLOCK: KINGSTON SECTION 26 BLOCK 21 UNIT 33
NAME(S): THE RESIDENT
ADDRESS: 33/43-51 GILES STREET
KINGSTON ACT 2604

312. BLOCK: KINGSTON SECTION 26 BLOCK 21 UNIT 34
NAME(S): THE RESIDENT
ADDRESS: 34/43-51 GILES STREET
KINGSTON ACT 2604

313. BLOCK: KINGSTON SECTION 26 BLOCK 21 UNIT 35
NAME(S): THE RESIDENT
ADDRESS: 35/43-51 GILES STREET
KINGSTON ACT 2604

314. BLOCK: KINGSTON SECTION 26 BLOCK 21 UNIT 36
NAME(S): THE RESIDENT
ADDRESS: 36/43-51 GILES STREET
KINGSTON ACT 2604

315. BLOCK: KINGSTON SECTION 26 BLOCK 21 UNIT 37

NAME(S): THE RESIDENT
ADDRESS: 37/41-53 GILES STREET
KINGSTON ACT 2604

316. BLOCK: KINGSTON SECTION 26 BLOCK 21 UNIT 38
NAME(S): THE RESIDENT
ADDRESS: 38/41-53 GILES STREET
KINGSTON ACT 2604

317. BLOCK: KINGSTON SECTION 26 BLOCK 21 UNIT 39
NAME(S): THE RESIDENT
ADDRESS: 39/41-53 GILES STREET
KINGSTON ACT 2604

318. BLOCK: KINGSTON SECTION 26 BLOCK 21 UNIT 40
NAME(S): THE RESIDENT
ADDRESS: 40/41-53 GILES STREET
KINGSTON ACT 2604

319. BLOCK: KINGSTON SECTION 26 BLOCK 21 UNIT 41
NAME(S): THE RESIDENT
ADDRESS: 41/41-53 GILES STREET
KINGSTON ACT 2604

320. BLOCK: KINGSTON SECTION 26 BLOCK 21 UNIT 42
NAME(S): THE RESIDENT
ADDRESS: 42/41-53 GILES STREET
KINGSTON ACT 2604

321. BLOCK: KINGSTON SECTION 26 BLOCK 21 UNIT 43
NAME(S): THE RESIDENT
ADDRESS: 43/41-53 GILES STREET
KINGSTON ACT 2604

322. BLOCK: KINGSTON SECTION 26 BLOCK 21 UNIT 44
NAME(S): THE RESIDENT
ADDRESS: 44/43-51 GILES STREET
KINGSTON ACT 2604

323. BLOCK: KINGSTON SECTION 26 BLOCK 21 UNIT 45
NAME(S): THE RESIDENT
ADDRESS: 45/43 GILES STREET
KINGSTON ACT 2604

324. BLOCK: KINGSTON SECTION 26 BLOCK 21 UNIT 46
NAME(S): THE RESIDENT
ADDRESS: 46/43-51 GILES STREET
KINGSTON ACT 2604

325. BLOCK: KINGSTON SECTION 26 BLOCK 21 UNIT 47
NAME(S): THE RESIDENT
ADDRESS: 47/43-51 GILES STREET
KINGSTON ACT 2604

326. BLOCK: KINGSTON SECTION 26 BLOCK 21 UNIT 48
NAME(S): THE RESIDENT
ADDRESS: 48/41-53 GILES STREET
KINGSTON ACT 2604

327. BLOCK: KINGSTON SECTION 26 BLOCK 21 UNIT 49

NAME(S): [REDACTED]
ADDRESS: [REDACTED]

328. BLOCK: KINGSTON SECTION 26 BLOCK 21 UNIT 49
NAME(S): THE RESIDENT
ADDRESS: 49/41-53 GILES STREET
KINGSTON ACT 2604

329. BLOCK: KINGSTON SECTION 26 BLOCK 21 UNIT 11
NAME(S): [REDACTED]
ADDRESS: [REDACTED]

330. BLOCK: KINGSTON SECTION 26 BLOCK 21 UNIT 46
NAME(S): [REDACTED]
ADDRESS: 27/51 GILES STREET
KINGSTON ACT 2604

331. BLOCK: KINGSTON SECTION 26 BLOCK 21 UNIT 48
NAME(S): [REDACTED]
ADDRESS: [REDACTED]

332. BLOCK: KINGSTON SECTION 26 BLOCK 21 UNIT 19
NAME(S): [REDACTED]
ADDRESS: [REDACTED]

333. BLOCK: KINGSTON SECTION 26 BLOCK 21 UNIT 13
NAME(S): [REDACTED]
ADDRESS: 13A/43-51 GILES STREET
KINGSTON ACT 2604

334. BLOCK: KINGSTON SECTION 26 BLOCK 21 UNIT 17
NAME(S): [REDACTED]
ADDRESS: 17A/43-51 GILES STREET
KINGSTON ACT 2604

335. BLOCK: KINGSTON SECTION 26 BLOCK 21 UNIT 40
NAME(S): [REDACTED]
ADDRESS: 40/41-53 GILES STREET
KINGSTON ACT 2604

336. BLOCK: KINGSTON SECTION 26 BLOCK 21 UNIT 10
NAME(S): [REDACTED]
ADDRESS: [REDACTED]

337. BLOCK: KINGSTON SECTION 26 BLOCK 21 UNIT 17
NAME(S): [REDACTED]
ADDRESS: 17A/43-51 GILES STREET
KINGSTON ACT 2604

338. BLOCK: KINGSTON SECTION 26 BLOCK 21 UNIT 36
NAME(S): [REDACTED]
ADDRESS: 10/43-51 GILES STREET
KINGSTON ACT 2604

339. BLOCK: KINGSTON SECTION 26 BLOCK 21 UNIT 37

NAME(S): [REDACTED]
ADDRESS: [REDACTED]

340. BLOCK: KINGSTON SECTION 26 BLOCK 21 UNIT 14
NAME(S): [REDACTED]
ADDRESS: 14/43-51 GILES STREET
KINGSTON ACT 2604

341. BLOCK: KINGSTON SECTION 26 BLOCK 21 UNIT 24
NAME(S): [REDACTED]
ADDRESS: [REDACTED]

342. BLOCK: KINGSTON SECTION 26 BLOCK 21 UNIT 28
NAME(S): [REDACTED]
ADDRESS: [REDACTED]

343. BLOCK: KINGSTON SECTION 26 BLOCK 21 UNIT 15
NAME(S): [REDACTED]
ADDRESS: 15A WENTWORTH CIRCUIT
KINGSTON ACT 2604

344. BLOCK: KINGSTON SECTION 26 BLOCK 21 UNIT 27
NAME(S): [REDACTED]
ADDRESS: [REDACTED]

345. BLOCK: KINGSTON SECTION 26 BLOCK 21 UNIT 20
NAME(S): [REDACTED]
ADDRESS: [REDACTED]

346. BLOCK: KINGSTON SECTION 26 BLOCK 21 UNIT 42
NAME(S): [REDACTED]
ADDRESS: [REDACTED]

347. BLOCK: KINGSTON SECTION 26 BLOCK 21 UNIT 43
NAME(S): [REDACTED]
ADDRESS: [REDACTED]

348. BLOCK: KINGSTON SECTION 26 BLOCK 21 UNIT 21
NAME(S): [REDACTED]
ADDRESS: [REDACTED]

349. BLOCK: KINGSTON SECTION 26 BLOCK 21 UNIT 40
NAME(S): [REDACTED]
ADDRESS: 40/41-53 GILES STREET
KINGSTON ACT 2604

350. BLOCK: KINGSTON SECTION 26 BLOCK 21 UNIT 49
NAME(S): [REDACTED]
ADDRESS: 11 WENTWORTH COURT 51 GILES STREET
KINGSTON ACT 2604

351. BLOCK: KINGSTON SECTION 26 BLOCK 21 UNIT 38

NAME(S): [REDACTED]
ADDRESS: 15/43-51 GILES STREET
KINGSTON ACT 2604

352. BLOCK: KINGSTON SECTION 26 BLOCK 21 UNIT 22
NAME(S): [REDACTED]
ADDRESS: 22/51 GILES STREET
KINGSTON ACT 2604

353. BLOCK: KINGSTON SECTION 26 BLOCK 21 UNIT 3
NAME(S): [REDACTED]
ADDRESS: [REDACTED]

354. BLOCK: KINGSTON SECTION 26 BLOCK 21 UNIT 3
NAME(S): THE RESIDENT
ADDRESS: 3/43-51 GILES STREET
KINGSTON ACT 2604

355. BLOCK: KINGSTON SECTION 26 BLOCK 21 UNIT 4
NAME(S): THE RESIDENT
ADDRESS: 4/43-51 GILES STREET
KINGSTON ACT 2604

356. BLOCK: KINGSTON SECTION 26 BLOCK 21 UNIT 18
NAME(S): [REDACTED]
ADDRESS: [REDACTED]

357. BLOCK: KINGSTON SECTION 26 BLOCK 21 UNIT 22
NAME(S): [REDACTED]
ADDRESS: 22/51 GILES STREET
KINGSTON ACT 2604

358. BLOCK: KINGSTON SECTION 26 BLOCK 21 UNIT 45
NAME(S): [REDACTED]
ADDRESS: [REDACTED]

359. BLOCK: KINGSTON SECTION 26 BLOCK 21 UNIT 4
NAME(S): [REDACTED]
ADDRESS: 4A/43-51 GILES STREET
KINGSTON ACT 2604

360. BLOCK: KINGSTON SECTION 26 BLOCK 21 UNIT 5
NAME(S): [REDACTED]
ADDRESS: [REDACTED]

361. BLOCK: KINGSTON SECTION 26 BLOCK 21 UNIT 7
NAME(S): THE RESIDENT
ADDRESS: 7/43-51 GILES STREET
KINGSTON ACT 2604

362. BLOCK: KINGSTON SECTION 26 BLOCK 21 UNIT 8
NAME(S): THE RESIDENT
ADDRESS: 8/43-51 GILES STREET
KINGSTON ACT 2604

363. BLOCK: KINGSTON SECTION 26 BLOCK 21 UNIT 9

NAME(S): THE RESIDENT
ADDRESS: 9/43-51 GILES STREET
KINGSTON ACT 2604

364. BLOCK: KINGSTON SECTION 26 BLOCK 21 UNIT 7
NAME(S): [REDACTED]
ADDRESS: [REDACTED]

365. BLOCK: KINGSTON SECTION 26 BLOCK 21 UNIT 6
NAME(S): [REDACTED]
ADDRESS: [REDACTED]

366. BLOCK: KINGSTON SECTION 26 BLOCK 21 UNIT 3
NAME(S): [REDACTED]
ADDRESS: [REDACTED]

367. BLOCK: KINGSTON SECTION 26 BLOCK 21 UNIT 35
NAME(S): [REDACTED]
ADDRESS: 8/43-51 GILES STREET
KINGSTON ACT 2604

368. BLOCK: KINGSTON SECTION 26 BLOCK 21 UNIT 4
NAME(S): [REDACTED]
ADDRESS: 4A/43-51 GILES STREET
KINGSTON ACT 2604

369. BLOCK: KINGSTON SECTION 26 BLOCK 21 UNIT 33
NAME(S): [REDACTED]
ADDRESS: [REDACTED]

370. BLOCK: KINGSTON SECTION 26 BLOCK 21 UNIT 29
NAME(S): [REDACTED]
ADDRESS: [REDACTED]

371. BLOCK: KINGSTON SECTION 26 BLOCK 21 UNIT 44
NAME(S): [REDACTED]
ADDRESS: [REDACTED]

372. BLOCK: KINGSTON SECTION 26 BLOCK 21 UNIT 31
NAME(S): [REDACTED]
ADDRESS: [REDACTED]

373. BLOCK: KINGSTON SECTION 26 BLOCK 21 UNIT 41
NAME(S): [REDACTED]
ADDRESS: [REDACTED]

374. BLOCK: KINGSTON SECTION 26 BLOCK 21 UNIT 47
NAME(S): [REDACTED]
ADDRESS: [REDACTED]

375. BLOCK: KINGSTON SECTION 26 BLOCK 21 UNIT 32

NAME(S): [REDACTED]
ADDRESS: [REDACTED]

376. BLOCK: KINGSTON SECTION 26 BLOCK 21 UNIT 30
NAME(S): [REDACTED]
ADDRESS: [REDACTED]

377. BLOCK: KINGSTON SECTION 26 BLOCK 21 UNIT 23
NAME(S): [REDACTED]
ADDRESS: 23/0 WENTWORTH CIRCUIT
KINGSTON ACT 2604

378. BLOCK: KINGSTON SECTION 26 BLOCK 21 UNIT 26
NAME(S): [REDACTED]
ADDRESS: UNIT 26A WENTWORTH CIRCUIT
KINGSTON ACT 2604

379. BLOCK: KINGSTON SECTION 26 BLOCK 21 UNIT 16
NAME(S): [REDACTED]
ADDRESS: [REDACTED]

380. BLOCK: KINGSTON SECTION 26 BLOCK 21 UNIT 39
NAME(S): [REDACTED]
ADDRESS: 39/41-53 GILES STREET
KINGSTON ACT 2604

381. BLOCK: KINGSTON SECTION 26 BLOCK 21 UNIT 25
NAME(S): [REDACTED]
ADDRESS: [REDACTED]

382. BLOCK: KINGSTON SECTION 26 BLOCK 21 UNIT 27
NAME(S): [REDACTED]
ADDRESS: [REDACTED]

383. BLOCK: KINGSTON SECTION 26 BLOCK 21
NAME(S): THE OWNERS - UNITS PLAN NO 666
ADDRESS: 43-51 GILES STREET
KINGSTON ACT 2604

384. BLOCK: KINGSTON SECTION 26 BLOCK 21 UNIT 8
NAME(S): [REDACTED]
ADDRESS: [REDACTED]

385. BLOCK: KINGSTON SECTION 26 BLOCK 21 UNIT 34
NAME(S): [REDACTED]
ADDRESS: [REDACTED]

386. BLOCK: KINGSTON SECTION 26 BLOCK 21 UNIT 12
NAME(S): [REDACTED]
ADDRESS: [REDACTED]

387. BLOCK: KINGSTON SECTION 26 BLOCK 21 UNIT 46

NAME(S): [REDACTED]
ADDRESS: 27/51 GILES STREET
KINGSTON ACT 2604

388. BLOCK: KINGSTON SECTION 26 BLOCK 21 UNIT 44
NAME(S): [REDACTED]
ADDRESS: [REDACTED]

389. BLOCK: KINGSTON SECTION 26 BLOCK 21 UNIT 1
NAME(S): [REDACTED]
ADDRESS: 1/43 GILES STREET
KINGSTON ACT 2604

390. BLOCK: KINGSTON SECTION 26 BLOCK 21 UNIT 2
NAME(S): [REDACTED]
ADDRESS: [REDACTED]

391. BLOCK: KINGSTON SECTION 26 BLOCK 21 UNIT 5
NAME(S): THE RESIDENT
ADDRESS: 5/43-51 GILES STREET
KINGSTON ACT 2604

392. BLOCK: KINGSTON SECTION 26 BLOCK 21 UNIT 6
NAME(S): THE RESIDENT
ADDRESS: 6/41-53 GILES STREET
KINGSTON ACT 2604

393. BLOCK: KINGSTON SECTION 26 BLOCK 21 UNIT 9
NAME(S): [REDACTED]
ADDRESS: [REDACTED]

394. BLOCK: KINGSTON SECTION 45 BLOCK 1 UNIT 1
NAME(S): THE RESIDENT
ADDRESS: 1/61-63 GILES STREET
KINGSTON ACT 2604

395. BLOCK: KINGSTON SECTION 45 BLOCK 1 UNIT 10
NAME(S): THE RESIDENT
ADDRESS: 10/61-63 GILES STREET
KINGSTON ACT 2604

396. BLOCK: KINGSTON SECTION 45 BLOCK 1 UNIT 11
NAME(S): THE RESIDENT
ADDRESS: 11/61-63 GILES STREET
KINGSTON ACT 2604

397. BLOCK: KINGSTON SECTION 45 BLOCK 1 UNIT 12
NAME(S): THE RESIDENT
ADDRESS: 12/61-63 GILES STREET
KINGSTON ACT 2604

398. BLOCK: KINGSTON SECTION 45 BLOCK 1 UNIT 13
NAME(S): THE RESIDENT
ADDRESS: 13/61-63 GILES STREET
KINGSTON ACT 2604

399. BLOCK: KINGSTON SECTION 45 BLOCK 1 UNIT 14

NAME(S): THE RESIDENT
ADDRESS: 14/61-63 GILES STREET
KINGSTON ACT 2604

400. BLOCK: KINGSTON SECTION 45 BLOCK 1 UNIT 15
NAME(S): THE RESIDENT
ADDRESS: 15/61-63 GILES STREET
KINGSTON ACT 2604

401. BLOCK: KINGSTON SECTION 45 BLOCK 1 UNIT 16
NAME(S): THE RESIDENT
ADDRESS: 16/61-63 GILES STREET
KINGSTON ACT 2604

402. BLOCK: KINGSTON SECTION 45 BLOCK 1 UNIT 17
NAME(S): THE RESIDENT
ADDRESS: 17/61-63 GILES STREET
KINGSTON ACT 2604

403. BLOCK: KINGSTON SECTION 45 BLOCK 1 UNIT 18
NAME(S): THE RESIDENT
ADDRESS: 18/61-63 GILES STREET
KINGSTON ACT 2604

404. BLOCK: KINGSTON SECTION 45 BLOCK 1 UNIT 19
NAME(S): THE RESIDENT
ADDRESS: 19/63 GILES STREET
KINGSTON ACT 2604

405. BLOCK: KINGSTON SECTION 45 BLOCK 1 UNIT 2
NAME(S): THE RESIDENT
ADDRESS: 2/61-63 GILES STREET
KINGSTON ACT 2604

406. BLOCK: KINGSTON SECTION 45 BLOCK 1 UNIT 20
NAME(S): THE RESIDENT
ADDRESS: 20/61-63 GILES STREET
KINGSTON ACT 2604

407. BLOCK: KINGSTON SECTION 45 BLOCK 1 UNIT 21
NAME(S): THE RESIDENT
ADDRESS: 21/61-63 GILES STREET
KINGSTON ACT 2604

408. BLOCK: KINGSTON SECTION 45 BLOCK 1 UNIT 22
NAME(S): THE RESIDENT
ADDRESS: 22/61-63 GILES STREET
KINGSTON ACT 2604

409. BLOCK: KINGSTON SECTION 45 BLOCK 1 UNIT 23
NAME(S): THE RESIDENT
ADDRESS: 23/61-63 GILES STREET
KINGSTON ACT 2604

410. BLOCK: KINGSTON SECTION 45 BLOCK 1 UNIT 24
NAME(S): THE RESIDENT
ADDRESS: 24/61-63 GILES STREET
KINGSTON ACT 2604

411. BLOCK: KINGSTON SECTION 45 BLOCK 1 UNIT 26

NAME(S): THE RESIDENT
ADDRESS: 26/61-63 GILES STREET
KINGSTON ACT 2604

412. BLOCK: KINGSTON SECTION 45 BLOCK 1 UNIT 27
NAME(S): THE RESIDENT
ADDRESS: 27/61-63 GILES STREET
KINGSTON ACT 2604

413. BLOCK: KINGSTON SECTION 45 BLOCK 1 UNIT 28
NAME(S): THE RESIDENT
ADDRESS: 28/61-63 GILES STREET
KINGSTON ACT 2604

414. BLOCK: KINGSTON SECTION 45 BLOCK 1 UNIT 29
NAME(S): THE RESIDENT
ADDRESS: 29/61-63 GILES STREET
KINGSTON ACT 2604

415. BLOCK: KINGSTON SECTION 45 BLOCK 1 UNIT 3
NAME(S): THE RESIDENT
ADDRESS: 3/61-63 GILES STREET
KINGSTON ACT 2604

416. BLOCK: KINGSTON SECTION 45 BLOCK 1 UNIT 30
NAME(S): THE RESIDENT
ADDRESS: 30/61-63 GILES STREET
KINGSTON ACT 2604

417. BLOCK: KINGSTON SECTION 45 BLOCK 1 UNIT 31
NAME(S): THE RESIDENT
ADDRESS: 31/61-63 GILES STREET
KINGSTON ACT 2604

418. BLOCK: KINGSTON SECTION 45 BLOCK 1 UNIT 32
NAME(S): THE RESIDENT
ADDRESS: 32/61-63 GILES STREET
KINGSTON ACT 2604

419. BLOCK: KINGSTON SECTION 45 BLOCK 1 UNIT 33
NAME(S): THE RESIDENT
ADDRESS: 33/61-63 GILES STREET
KINGSTON ACT 2604

420. BLOCK: KINGSTON SECTION 45 BLOCK 1 UNIT 34
NAME(S): THE RESIDENT
ADDRESS: 34/61-63 GILES STREET
KINGSTON ACT 2604

421. BLOCK: KINGSTON SECTION 45 BLOCK 1 UNIT 35
NAME(S): THE RESIDENT
ADDRESS: 35/61-63 GILES STREET
KINGSTON ACT 2604

422. BLOCK: KINGSTON SECTION 45 BLOCK 1 UNIT 36
NAME(S): THE RESIDENT
ADDRESS: 36/61-63 GILES STREET
KINGSTON ACT 2604

423. BLOCK: KINGSTON SECTION 45 BLOCK 1 UNIT 37

NAME(S): THE RESIDENT
ADDRESS: 37/61-63 GILES STREET
KINGSTON ACT 2604

424. BLOCK: KINGSTON SECTION 45 BLOCK 1 UNIT 38
NAME(S): THE RESIDENT
ADDRESS: 38/61-63 GILES STREET
KINGSTON ACT 2604

425. BLOCK: KINGSTON SECTION 45 BLOCK 1 UNIT 39
NAME(S): THE RESIDENT
ADDRESS: 39/61-63 GILES STREET
KINGSTON ACT 2604

426. BLOCK: KINGSTON SECTION 45 BLOCK 1 UNIT 4
NAME(S): THE RESIDENT
ADDRESS: 4/61-63 GILES STREET
KINGSTON ACT 2604

427. BLOCK: KINGSTON SECTION 45 BLOCK 1 UNIT 40
NAME(S): THE RESIDENT
ADDRESS: 40/61-63 GILES STREET
KINGSTON ACT 2604

428. BLOCK: KINGSTON SECTION 45 BLOCK 1 UNIT 41
NAME(S): THE RESIDENT
ADDRESS: 41/-67 GILES STREET
KINGSTON ACT 2604

429. BLOCK: KINGSTON SECTION 45 BLOCK 1 UNIT 42
NAME(S): THE RESIDENT
ADDRESS: 42/61-63 GILES STREET
KINGSTON ACT 2604

430. BLOCK: KINGSTON SECTION 45 BLOCK 1 UNIT 43
NAME(S): THE RESIDENT
ADDRESS: 43/61-67 GILES STREET
KINGSTON ACT 2604

431. BLOCK: KINGSTON SECTION 45 BLOCK 1 UNIT 44
NAME(S): THE RESIDENT
ADDRESS: 44/61-63 GILES STREET
KINGSTON ACT 2604

432. BLOCK: KINGSTON SECTION 45 BLOCK 1 UNIT 45
NAME(S): THE RESIDENT
ADDRESS: 45/61-63 GILES STREET
KINGSTON ACT 2604

433. BLOCK: KINGSTON SECTION 45 BLOCK 1 UNIT 5
NAME(S): THE RESIDENT
ADDRESS: 5/61-63 GILES STREET
KINGSTON ACT 2604

434. BLOCK: KINGSTON SECTION 45 BLOCK 1 UNIT 6
NAME(S): THE RESIDENT
ADDRESS: 6/61-63 GILES STREET
KINGSTON ACT 2604

435. BLOCK: KINGSTON SECTION 45 BLOCK 1



NAME(S): THE RESIDENT
ADDRESS: 61-63 GILES STREET
KINGSTON ACT 2604



436. BLOCK: KINGSTON SECTION 45 BLOCK 1 UNIT 7
NAME(S): THE RESIDENT
ADDRESS: 7/61-63 GILES STREET
KINGSTON ACT 2604



437. BLOCK: KINGSTON SECTION 45 BLOCK 1 UNIT 8
NAME(S): THE RESIDENT
ADDRESS: 8/61-63 GILES STREET
KINGSTON ACT 2604



438. BLOCK: KINGSTON SECTION 45 BLOCK 1 UNIT 9
NAME(S): THE RESIDENT
ADDRESS: 9/61-63 GILES STREET
KINGSTON ACT 2604



439. BLOCK: KINGSTON SECTION 45 BLOCK 1
NAME(S): THE RESIDENT
ADDRESS: I-63 GILES STREET
KINGSTON ACT 2604



440. BLOCK: KINGSTON SECTION 45 BLOCK 1 UNIT 44
NAME(S): 
ADDRESS: 



441. BLOCK: KINGSTON SECTION 45 BLOCK 1 UNIT 15
NAME(S): 
ADDRESS: 

442. BLOCK: KINGSTON SECTION 45 BLOCK 1 UNIT 36
NAME(S): 
ADDRESS: 

443. BLOCK: KINGSTON SECTION 45 BLOCK 1 UNIT 13
NAME(S): 
ADDRESS: 

444. BLOCK: KINGSTON SECTION 45 BLOCK 1 UNIT 17
NAME(S): 
ADDRESS: 

445. BLOCK: KINGSTON SECTION 45 BLOCK 1 UNIT 3
NAME(S): 
ADDRESS: 

446. BLOCK: KINGSTON SECTION 45 BLOCK 1 UNIT 31
NAME(S): 
ADDRESS: 

447. BLOCK: KINGSTON SECTION 45 BLOCK 1 UNIT 45

NAME(S): [REDACTED]
ADDRESS: [REDACTED]

448. BLOCK: KINGSTON SECTION 45 BLOCK 1 UNIT 15
NAME(S): [REDACTED]
ADDRESS: [REDACTED]

449. BLOCK: KINGSTON SECTION 45 BLOCK 1 UNIT 30
NAME(S): [REDACTED]
ADDRESS: [REDACTED]

450. BLOCK: KINGSTON SECTION 45 BLOCK 1 UNIT 26
NAME(S): [REDACTED]
ADDRESS: 99/61 GILES STREET
KINGSTON ACT 2604

451. BLOCK: KINGSTON SECTION 45 BLOCK 1 UNIT 12
NAME(S): [REDACTED]
ADDRESS: [REDACTED]

452. BLOCK: KINGSTON SECTION 45 BLOCK 1 UNIT 43
NAME(S): [REDACTED]
ADDRESS: 33 JARDINE STREET
KINGSTON ACT 2604

453. BLOCK: KINGSTON SECTION 45 BLOCK 1 UNIT 4
NAME(S): [REDACTED]
ADDRESS: [REDACTED]

454. BLOCK: KINGSTON SECTION 45 BLOCK 1 UNIT 39
NAME(S): [REDACTED]
ADDRESS: [REDACTED]

455. BLOCK: KINGSTON SECTION 45 BLOCK 1 UNIT 26
NAME(S): [REDACTED]
ADDRESS: 99/61 GILES STREET
KINGSTON ACT 2604

456. BLOCK: KINGSTON SECTION 45 BLOCK 1 UNIT 27
NAME(S): [REDACTED]
ADDRESS: [REDACTED]

457. BLOCK: KINGSTON SECTION 45 BLOCK 1 UNIT 11
NAME(S): [REDACTED]
ADDRESS: [REDACTED]

458. BLOCK: KINGSTON SECTION 45 BLOCK 1 UNIT 6
NAME(S): [REDACTED]
ADDRESS: [REDACTED]

459. BLOCK: KINGSTON SECTION 45 BLOCK 1 UNIT 5

NAME(S): [REDACTED]
ADDRESS: [REDACTED]

460. BLOCK: KINGSTON SECTION 45 BLOCK 1 UNIT 6
NAME(S): [REDACTED]
ADDRESS: [REDACTED]

461. BLOCK: KINGSTON SECTION 45 BLOCK 1 UNIT 33
NAME(S): [REDACTED]
ADDRESS: 103/63 GILES STREET
KINGSTON ACT 2604

462. BLOCK: KINGSTON SECTION 45 BLOCK 1 UNIT 6
NAME(S): [REDACTED]
ADDRESS: [REDACTED]

463. BLOCK: KINGSTON SECTION 45 BLOCK 1 UNIT 23
NAME(S): [REDACTED]
ADDRESS: [REDACTED]

464. BLOCK: KINGSTON SECTION 45 BLOCK 1 UNIT 3
NAME(S): [REDACTED]
ADDRESS: [REDACTED]

465. BLOCK: KINGSTON SECTION 45 BLOCK 1 UNIT 29
NAME(S): [REDACTED]
ADDRESS: 95/61 GILES STREET
KINGSTON ACT 2604

466. BLOCK: KINGSTON SECTION 45 BLOCK 1 UNIT 9
NAME(S): [REDACTED]
ADDRESS: 7/67 GILES STREET
KINGSTON ACT 2604

467. BLOCK: KINGSTON SECTION 45 BLOCK 1 UNIT 29
NAME(S): [REDACTED]
ADDRESS: 95/61 GILES STREET
KINGSTON ACT 2604

468. BLOCK: KINGSTON SECTION 45 BLOCK 1 UNIT 32
NAME(S): [REDACTED]
ADDRESS: 102/63 GILES STREET
KINGSTON ACT 2604

469. BLOCK: KINGSTON SECTION 45 BLOCK 1 UNIT 14
NAME(S): [REDACTED]
ADDRESS: 54/61 GILES STREET
KINGSTON ACT 2604

470. BLOCK: KINGSTON SECTION 45 BLOCK 1 UNIT 42
NAME(S): [REDACTED]
ADDRESS: [REDACTED]

471. BLOCK: KINGSTON SECTION 45 BLOCK 1 UNIT 19

NAME(S): [REDACTED]
ADDRESS: 56/63 GILES STREET
KINGSTON ACT 2604

472. BLOCK: KINGSTON SECTION 45 BLOCK 1 UNIT 34
NAME(S): [REDACTED]
ADDRESS: [REDACTED]

473. BLOCK: KINGSTON SECTION 45 BLOCK 1 UNIT 22
NAME(S): [REDACTED]
ADDRESS: [REDACTED]

474. BLOCK: KINGSTON SECTION 45 BLOCK 1 UNIT 34
NAME(S): [REDACTED]
ADDRESS: [REDACTED]

475. BLOCK: KINGSTON SECTION 45 BLOCK 1 UNIT 28
NAME(S): [REDACTED]
ADDRESS: 101/61 GILES STREET
KINGSTON ACT 2604

476. BLOCK: KINGSTON SECTION 45 BLOCK 1 UNIT 16
NAME(S): [REDACTED]
ADDRESS: [REDACTED]

477. BLOCK: KINGSTON SECTION 45 BLOCK 1 UNIT 10
NAME(S): [REDACTED]
ADDRESS: 8/67 GILES STREET
KINGSTON ACT 2604

478. BLOCK: KINGSTON SECTION 45 BLOCK 1 UNIT 35
NAME(S): [REDACTED]
ADDRESS: 105/65 GILES STREET
KINGSTON ACT 2604

479. BLOCK: KINGSTON SECTION 45 BLOCK 1 UNIT 18
NAME(S): [REDACTED]
ADDRESS: [REDACTED]

480. BLOCK: KINGSTON SECTION 45 BLOCK 1 UNIT 21
NAME(S): [REDACTED]
ADDRESS: [REDACTED]

481. BLOCK: KINGSTON SECTION 45 BLOCK 1 UNIT 7
NAME(S): [REDACTED]
ADDRESS: 5/65 GILES STREET
KINGSTON ACT 2604

482. BLOCK: KINGSTON SECTION 45 BLOCK 1 UNIT 20
NAME(S): [REDACTED]
ADDRESS: 57/65 GILES STREET
KINGSTON ACT 2604

483. BLOCK: KINGSTON SECTION 45 BLOCK 1 UNIT 2

NAME(S): [REDACTED]
ADDRESS: [REDACTED]

484. BLOCK: KINGSTON SECTION 45 BLOCK 1 UNIT 40
NAME(S): [REDACTED]
ADDRESS: 40/61-63 GILES STREET
KINGSTON ACT 2604

485. BLOCK: KINGSTON SECTION 45 BLOCK 1 UNIT 10
NAME(S): [REDACTED]
ADDRESS: 8/67 GILES STREET
KINGSTON ACT 2604

486. BLOCK: KINGSTON SECTION 45 BLOCK 1
NAME(S): [REDACTED]
ADDRESS: 98/61 GILES STREET
KINGSTON ACT 2604

487. BLOCK: KINGSTON SECTION 45 BLOCK 1 UNIT 45
NAME(S): [REDACTED]
ADDRESS: [REDACTED]

488. BLOCK: KINGSTON SECTION 45 BLOCK 1
NAME(S): THE OWNERS-UNITS PLAN NO 2728
ADDRESS: LOCKED BAG 6
DEAKIN ACT 2600

489. BLOCK: KINGSTON SECTION 45 BLOCK 1 UNIT 24
NAME(S): [REDACTED]
ADDRESS: [REDACTED]

490. BLOCK: KINGSTON SECTION 45 BLOCK 1 UNIT 1
NAME(S): [REDACTED]
ADDRESS: [REDACTED]

491. BLOCK: KINGSTON SECTION 45 BLOCK 1 UNIT 37
NAME(S): [REDACTED]
ADDRESS: 37/61-63 GILES STREET
KINGSTON ACT 2604

492. BLOCK: KINGSTON SECTION 45 BLOCK 1 UNIT 8
NAME(S): [REDACTED]
ADDRESS: [REDACTED]

493. BLOCK: KINGSTON SECTION 45 BLOCK 1 UNIT 44
NAME(S): [REDACTED]
ADDRESS: [REDACTED]

494. BLOCK: KINGSTON SECTION 45 BLOCK 1 UNIT 38
NAME(S): [REDACTED]
ADDRESS: [REDACTED]

495. BLOCK: KINGSTON SECTION 45 BLOCK 1 UNIT 41