



ACT
Government

Justice and Community Safety

LIQUOR LICENCE

Liquor Act 2010

AUSTRALIAN CAPITAL TERRITORY

Licence Number: **13008799**

EMPIRE CUPPING ROOM PTY LTD

ACN 161 448 451

is licensed, under the provisions of the *Liquor Act 2010*, to supply liquor in the Australian Capital Territory within the restrictions of the following class of licence:

ON – Restaurant

Accordingly, liquor may be supplied in open containers for consumption on the premises between the hours of **7am** and **12am** at the following location:

1-12 University Avenue CITY ACT 2601
Block 5, Section 1, City

trading as:

The Cupping Room

This licence is valid for the period from **12 December 2013** to **30 November 2014** inclusive.

I approve the Licensed Premises Plans, attached to this licence, and it forms part of this licence.

This licence is subject to the conditions listed under the heading "Licence Conditions" and these conditions must be complied with.

Derise Cubin
Delegate of the Commissioner for Fair Trading
12 December 2013

Certificate

LICENCE CONDITIONS

Liquor Act 2010

The licence is subject to the Conditions identified in the *Liquor Act 2010*, section 31 and the *Liquor Regulation 2010*, Schedule 1. The following conditions apply to **EMPIRE CUPPING ROOM PTY LTD** in addition to those prescribed in the Act and Regulation.

- You must install electronic video surveillance to monitor the path to the toilet facilities by **1 March 2014**. The electronic video surveillance must include camera and a monitor displaying the path that can be seen by a staff member at the premises.
- You must ensure that you, your staff and the premises comply with the following Guidelines:
 - *Liquor (Intoxication) Guidelines 2010 (No 1)*;
 - *Liquor (Responsible Promotion of Liquor) Guidelines 2012 (No 1)*.

For access to the prescribed conditions visit www.legislation.act.gov.au.

CLOSE ASSOCIATES, INFLUENTIAL PERSONS & PERSONS WITH DAY-TO-DAY CONTROL

Licence Number: 13008799

With respect to the premises trading as

The Cupping Room

In accordance with the *Liquor Act 2010*, section 27 the following people are deemed to be a suitable person with respect to this licence.

Influential Persons

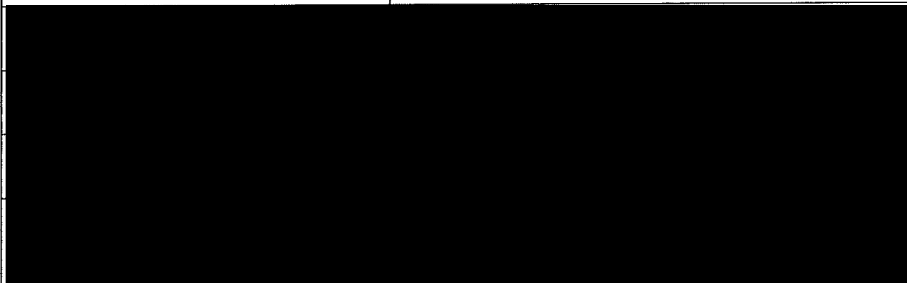
Name	Address	Relationship
		Director
		Director
		Director
		Director

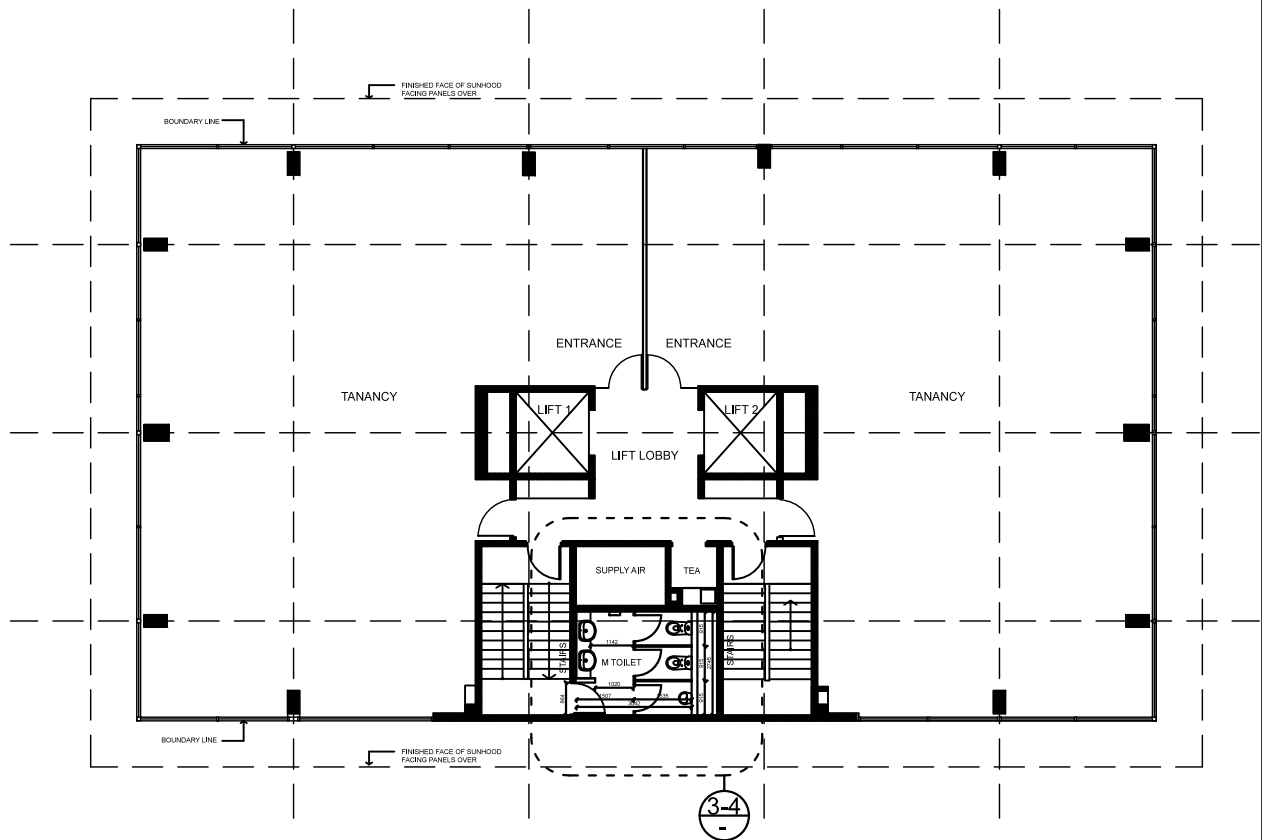

1 TYPICAL FLOOR PLAN
SCALE : 1/200

The area bounded by the red line is the area to which the licence applies.
Toilet Facilities
Licence Number 13008799.
The Cupping Room.

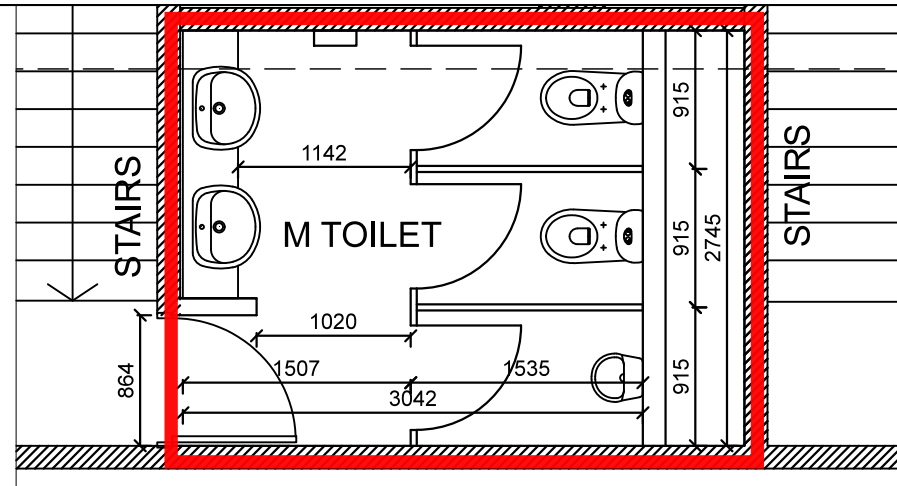

3 MALE TOILET FLOOR PLAN
MID-LEVEL BETWEEN GROUND AND FIRST LEVEL Scale : 1/50



4 FEMALE TOILET FLOOR PLAN
MID-LEVEL BETWEEN FIRST AND SECOND LEVEL Scale : 1/50

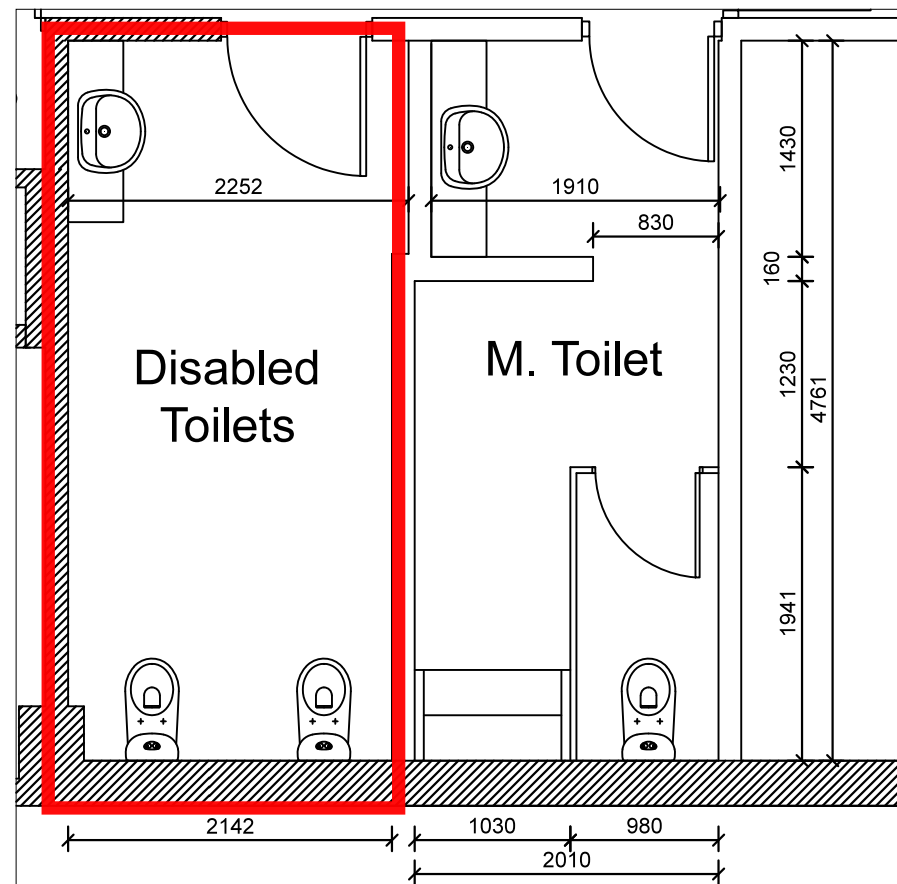

5 DISABLED AND MALE TOILET FLOOR PLAN
BASEMENT LEVEL Scale : 1/50

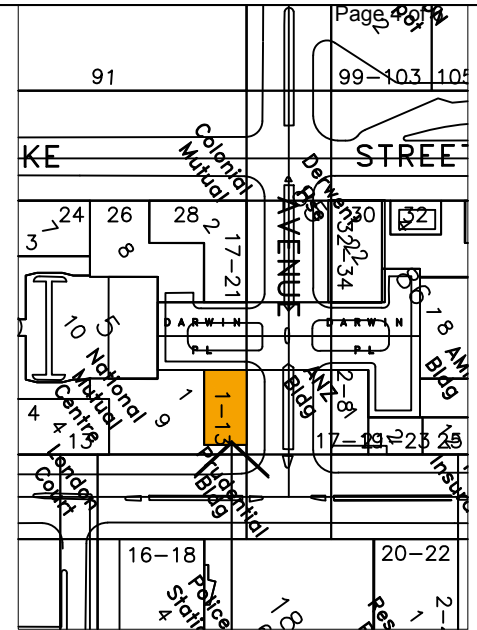

EMPIRE CHAMBERS
1-13 University Av CANBERRA
CITY ACT

FOR INFORMATION ONLY

Revision	Date
A	FOR INFORMATION 10.10.13



PROJECT
EMPIRE CHAMBERS
UNIT 5 / 1-13 University Av
CANBERRA CITY ACT
FIRST LEVEL

DRAWING TITLE
EXISTING TOILETS PLANS

DATE:
10.10.13

SCALE:
AS SHOWN

SK01

ISSUE
A

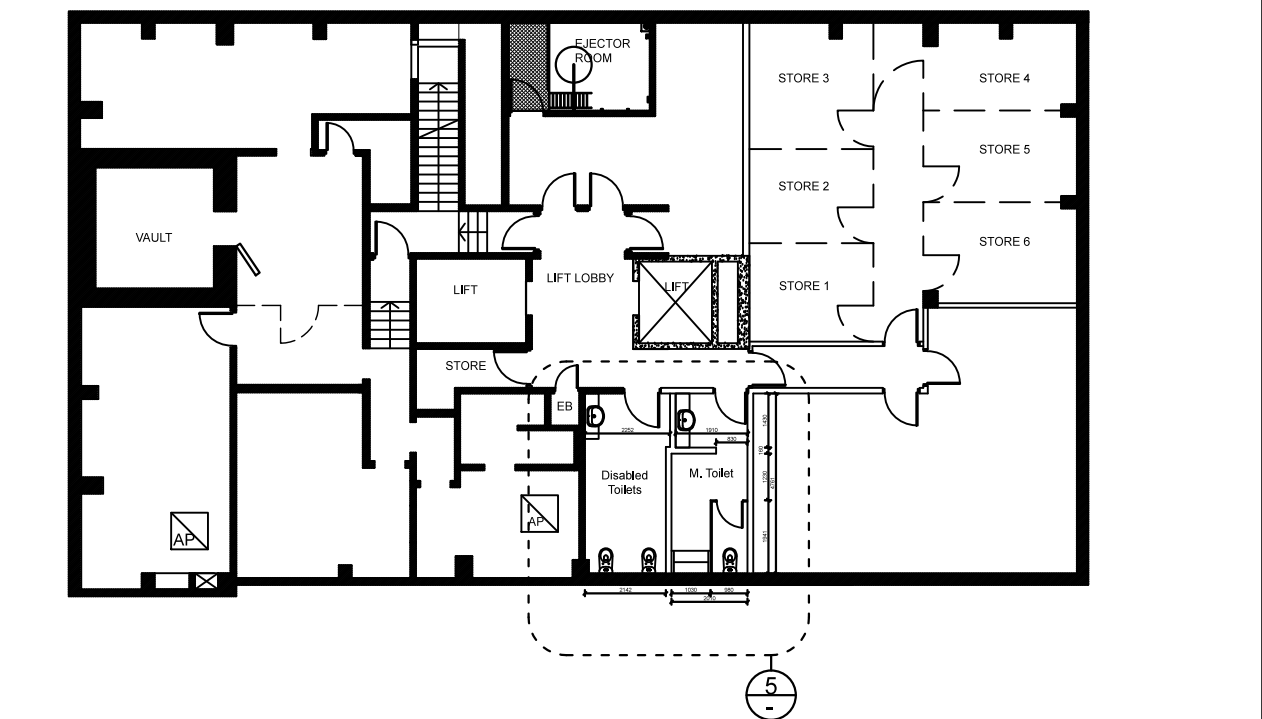

2 BASEMENT FLOOR PLAN
SCALE : 1/200

The Cupping Room proposed outdoor zones

- Currently approved zones
- Allowance for public space
- proposed added zoned area

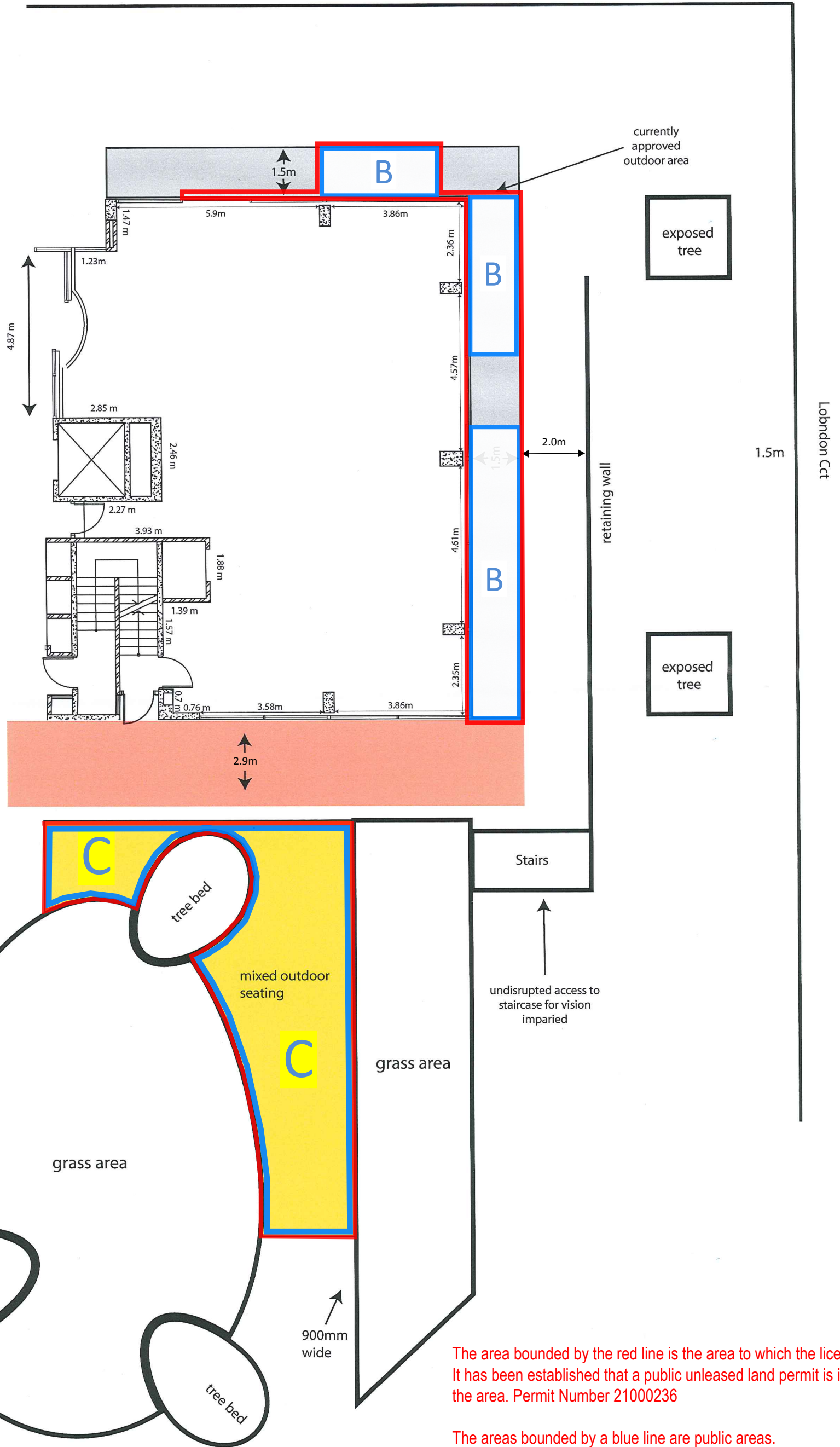

The area bounded by the red line is the area to which the licence applies. It has been established that a public unleased land permit is in force for the area. Permit Number 21000236

The areas bounded by a blue line are public areas. The occupancy loading for outdoor Area B is 22 persons. The occupancy loading for outdoor Area C is 52 persons.

Licence Number 13008799
The Cupping Room - November 2013

Ray White.

Canberra
Locked Bag 3008
Woden ACT 2606
tel 02 6162 0681
fax 02 6162 0682
client.services@rwcanberra.com.au
rwcanberra.com.au

Attn. Drazen Persic
Office of Regulatory Services – Liquor Licensing.
255 Canberra Avenue
Fyshwick ACT 2609

Dear Drazen,

RE –UP1714 “Empire Chambers” - 1-13 University Avenue Civic, ACT 2600

Ray White Strata are the managing agents for the above mentioned building and this letter is to advise the Owners Corporation have provided consent to the proprietors and patrons of “The Cupping Room” café, use of the common property toilets.

If you have any questions or concerns, please feel free to contact me on [REDACTED] or via email [REDACTED]

Yours Faithfully
RAY WHITE STRATA



[REDACTED]
11/12/2013