



ACT
Government

Chief Minister, Treasury and
Economic Development

Freedom of Information Publication Coversheet

The following information is provided pursuant to section 28 of the *Freedom of Information Act 2016*.

FOI Reference: CMTEDDFOI 2020-029

Information to be published	Status
1. Access application	Published
2. Decision notice	Published
3. Documents and schedule	Published
4. Additional information identified	No
5. Fees	N/A
6. Processing time (in working days)	31
7. Decision made by Ombudsman	N/A
8. Additional information identified by Ombudsman	N/A
9. Decision made by ACAT	N/A
10. Additional information identified by ACAT	N/A

From: [REDACTED]
To: [CMTEDD FOI](#)
Cc: [REDACTED]
Subject: Freedom of Information Request 18th February 2020
Date: Tuesday, 18 February 2020 2:28:10 PM

Dear Sir/Madam,

[REDACTED] seeks access to the following information under s7 of the *Freedom of Information Act 2016*:

- 1) Any records or documents produced or held by WorkSafe ACT relating to the Grand Central Towers building site in Phillip.
- 2) Any correspondence between WorkSafe ACT or its employees and any employee or agent of an entity in the GeoCon Group in relation to the Grand Central Towers building site in Phillip, between 1st August 2019 and 17th February 2020;
- 3) Any correspondence between WorkSafe ACT or its employees and any employee or agent of an entity in the Adcon Group in relation to the Grand Central Towers building site in Phillip, between 1st August 2019 and 17th February 2020;
- 4) Any other decisions, approvals or notices issued under the *Work Health and Safety Act 2011* in relation to the Grand Central Towers site, issued on or after 1st August 2019.

In relation to s7 of the *Freedom of Information Act 2016*, [REDACTED] considers that factors favouring the disclosure of the information include:

- 1) As they comprise decisions taken by a government agency, release of this information would enhance the government's accountability in line with Schedule 2, 2.1(a)(i);
- 2) This information would reveal the reason for one or more government decisions and any background or contextual information that informed the decision in line with Schedule 2, 2.1(a)(viii);
- 3) If released, this information, as it deals with construction works involving excavation, building, the removal of soil and potentially toxic sewerage works, would contribute to the protection of the environment, in line with Schedule 2, 2.1(a)(viii)'
- 4) If released, this information, as it deals with construction works and the safety of workers and the public, may reveal health risks or measures relating to public health and safety.

Contact details to respond to this request are:

Name: [REDACTED]

Email Address: [REDACTED]

Phone: [REDACTED]

[REDACTED]

If there are any queries or concerns about this request, or any way I can assist further, please give me call.

Cheers,



I acknowledge the traditional Aboriginal owners of country throughout the ACT and pay my respect to them, their culture and their Elders past, present and future.

Disclaimer: The information in this e-mail may be confidential and/or legally privileged. It is intended solely for the addressee. Access to this e-mail by anyone else is unauthorised. If you are not the intended recipient, any disclosure, copying, distribution or any action taken or omitted to be taken in reliance on it, is prohibited and may be unlawful.



ACT
Government

Chief Minister, Treasury and
Economic Development

Our ref: CMTEDDFOI 2020-029



FREEDOM OF INFORMATION REQUEST

I refer to your application under section 30 of the *Freedom of Information Act 2016* (the Act), received by the Chief Minister, Treasury and Economic Development Directorate (CMTEDD) on 18 February 2020, in which you sought access to the following:

 seeks access to the following information under s7 of the *Freedom of Information Act 2016*:

- 1) *Any records or documents produced or held by WorkSafe ACT relating to the Grand Central Towers building site in Phillip.*
- 2) *Any correspondence between WorkSafe ACT or its employees and any employee or agent of an entity in the GeoCon Group in relation to the Grand Central Towers building site in Phillip, between 1st August 2019 and 17th February 2020;*
- 3) *Any correspondence between WorkSafe ACT or its employees and any employee or agent of an entity in the Adcon Group in relation to the Grand Central Towers building site in Phillip, between 1st August 2019 and 17th February 2020;*
- 4) *Any other decisions, approvals or notices issued under the Work Health and Safety Act 2011 in relation to the Grand Central Towers site, issued on or after 1st August 2019."*

Authority

As an appointed Information Officer under section 18 of the Act, I am authorised to make a decision on access or amendment to government information in the possession or control of CMTEDD.

Timeframes

In accordance with section 40 of the Act, CMTEDD is required to provide a decision on your access application by 8 April 2020.

Third Party Consultation

In making this decision, third party consultation was completed in accordance with section 38 of the Act. The views of the relevant third parties were taken into consideration when making this decision.

Decision on access

Searches were completed for relevant documents and nine documents were identified that fall within the scope of your request.

I have included as **Attachment A** to this decision the schedule of relevant documents. This provides a description of each document that falls within the scope of your request and the access decision for each of those documents.

I have decided to grant access in full to two documents relevant to your request. I have decided to grant partial access to seven documents as I consider it to contain information that would, on balance, be contrary to the public interest to disclose under the test set out in section 17 of the Act.

My access decisions are detailed further in the following statement of reasons and the documents released to you are provided as **Attachment B** to this letter.

In accordance with section 54(2) of the Act a statement of reasons outlining my decisions is below.

Statement of Reasons

In reaching my access decisions, I have taken the following into account:

- the Act;
- the content of the documents that fall within the scope of your request;
- the views of the relevant third party; and
- the *Information Privacy Act 2014*.

Exemption claimed

My reasons for deciding not to grant access to the identified documents and components of these documents are as follows:

Public Interest

The Act has a presumption in favour of disclosure. As a decision maker I am required to decide where, on balance, public interests lies. As part of this process I must consider factors favouring disclosure and non-disclosure.

In *Hogan v Hinch* (2011) 243 CLR 506, [31] French CJ stated that when 'used in a statute, the term [public interest] derives its content from "the subject matter and the scope and purpose" of the enactment in which it appears'. Section 17(1) of the Act sets out the test, to be applied to determine whether disclosure of information would be contrary to the public interest. These factors are found in subsection 17(2) and Schedule 2 of the Act.

Taking into consideration the information contained in the documents found to be within the scope of your request, I have identified that the following public interest factors are relevant to determine if release of the information contained within these documents is within the 'public interest'.

Factors favouring disclosure in the public interest:

- (a) *disclosure of the information could reasonably be expected to do any of the following:*
(xiii) *contribute to the administration of justice generally, including procedural fairness.*

Having considered the factor above, I consider that the release of these documents may contribute to the administration of justice generally by allowing you to have a record of the WorkSafe ACT documents that fall under the scope of your request. However, this factor is to be balanced against the factors favouring non-disclosure.

Factors favouring nondisclosure in the public interest:

- (a) *disclosure of the information could reasonably be expected to do any of the following:*
(ii) *Prejudice the protection of an individual's right to privacy or other rights under the Human Rights Act 2004;*

Taking into account the submissions put to me by the relevant third parties as part of the consultation undertaken in accordance with section 38 of the Act and having reviewed the documents, I consider that the protection of an individual's right to privacy, especially in the course of dealings with the ACT Government is a significant factor as the parties involved have provided their personal information for the purposes of working with the ACT Government. This, in my opinion, outweighs the benefit which may be derived from releasing the personal information of the individual's involved in this matter.

Individuals are entitled to expect that the personal information they have supplied as part of this process will be dealt with in a manner that protects their privacy. Considering the type of information to be withheld from release, I am satisfied that the factors in favour of release can still be met while protecting the personal information of the individuals involved. I therefore weight the factor for non-disclosure more highly than the factor in favour of release in this instance. As a result, I have decided that release of this information (email addresses, mobile numbers and names of individuals not employed by the ACT Public Service) could prejudice their right to privacy under the *Human Rights Act 2004*.

Having applied the test outlined in section 17 of the Act and deciding that release of personal information contained in the documents is not in the public interest to release, I have redacted this information in seven of the documents in accordance with section 50(2). Noting the pro-disclosure intent of the Act, I am satisfied that redacting only the information that I believe is not in the public interest to release will ensure that the intent of the Act is met and will provide you with access to the majority of the information held by CMTEDD within the scope of your request.

Folios 1-6 and 9 of the identified documents contain information that I consider, on balance, to be contrary to the public interest to disclose under the test set out in section 17 of the Act or they contain information which is out of scope.

Charges

Pursuant to *Freedom of Information (Fees) Determination 2017 (No 2)* processing charges are not applicable for this request because the total number of pages to be released to you is below the charging threshold of 50 pages.

Online publishing – Disclosure Log

Under section 28 of the Act, CMTEDD maintains an online record of access applications called a disclosure log. Your original access application, my decision and documents released to you in response to your access application will be published in the CMTEDD disclosure log after three working days after the date of my decision. Your personal contact details will not be published. You may view CMTEDD disclosure log at:

<https://www.cmtedd.act.gov.au/functions/foi/disclosure-log-2020>.

Ombudsman Review

My decision on your access request is a reviewable decision as identified in Schedule 3 of the Act. You have the right to seek Ombudsman review of this outcome under section 73 of the Act within 20 working days from the day that my decision is published in CMTEDD disclosure log, or a longer period allowed by the Ombudsman.

We recommend using this form [Applying for an Ombudsman Review](#) to ensure you provide all of the required information. Alternatively, you may write to the Ombudsman at:

The ACT Ombudsman
GPO Box 442
CANBERRA ACT 2601

Via email: actfoi@ombudsman.gov.au

ACT Civil and Administrative Tribunal (ACAT) Review

Under section 84 of the Act, if a decision is made under section 82(1) on an Ombudsman review, you may apply to the ACAT for review of the Ombudsman decision. Further information may be obtained from the ACAT at:

ACT Civil and Administrative Tribunal
Level 4, 1 Moore St
GPO Box 370
Canberra City ACT 2601
Telephone: (02) 6207 1740
<http://www.acat.act.gov.au/>

Should you have any queries in relation to your request please contact me by telephone on 6207 7754 or email CMTEDDFOI@act.gov.au.

Yours sincerely

A handwritten signature in grey ink, appearing to read 'P. Dachs', is positioned above the typed name.

Philip Dachs
Information Officer
Information Access Team
Chief Minister, Treasury and Economic Development Directorate

2 April 2020



ACT
Government

Chief Minister, Treasury and
Economic Development

FREEDOM OF INFORMATION REQUEST SCHEDULE

WHAT ARE THE PARAMETERS OF THE REQUEST

Reference NO.

Any records or documents produced or held by WorkSafe ACT relating to the Grand Central Towers building site in Phillip. Any correspondence between WorkSafe ACT or its employees and any employee or agent of an entity in the GeoCon Group in relation to the Grand Central Towers building site in Phillip, between 1st August 2019 and 17th February 2020; Any correspondence between WorkSafe ACT or its employees and any employee or agent of an entity in the Adcon Group in relation to the Grand Central Towers building site in Phillip, between 1st August 2019 and 17th February 2020; Any other decisions, approvals or notices issued under the *Work Health and Safety Act 2011* in relation to the Grand Central Towers site, issued on or after 1st August 2019.

CMTEDDFOI 2020-029

Ref No	Page number	Description	Date	Status	Reason for Exemption	Online Release Status
1	1-4	WPV-P05757-VK0DM9 Workplace visit report	1 Aug 2019	Partial	Sch 2 s2.2 (a)(ii)	Yes
2	5-8	WPV-P05757-VMF6MR Workplace visit report	10 Dec 2019	Partial	Sch 2 s2.2 (a)(ii)	Yes
3	9-12	WPV-P05757-VMGOH2 Workplace visit report	13 Dec 2019	Partial	Sch 2 s2.2 (a)(ii)	Yes
4	13-16	Notifiable Incident Report	13 Dec 2019	Partial	Sch 2 s2.2 (a)(ii)	Yes
5	17-19	Improvement notice	16 Dec 2019	Partial	Sch 2 s2.2 (a)(ii)	Yes
6	20	Email – part of above Improvement notice	16 Dec 2019	Partial	Sch 2 s2.2 (a)(ii)	Yes
7	21-31	Photos as attachment to Improvement notice		Full		Yes
8	32-38	Plans as attachment to Improvement notice		Full		Yes
9	39-44	Issue notice report – WPV-P05757-VMGGO6	16 Dec 2019	Partial	Sch 2 s2.2 (a)(ii)	Yes
Total No of Docs						
9						

Initial information

Type of report *

Workp ace Visit

Inspector ID *

P05757

Inspection number

WPV-P05757-VK0DM9

Event number

190805-000039

Lead inspector *

A an Chipperfie d

Is there any accompanying inspectors *

Yes

No

Item Number 1

Accompanying inspector/Other *

Mason,F anagan & Dawson

Date *

01 Aug 2019

Time commenced *

11:15

Type of WPV *

Proactive

Reactive

Purpose of WPV *

Programmed Inspection

Legis ation *

Work Hea th and Safety Act 2011

Is this a joint inspection? *

Yes

No

Name of individua or registered company *

Geocon Constructors Pty Ltd

ABN

86126126850

ACN

Business or trading name (if different)

Registered company address

Address line 1 *

Unit 18, Level 1, 24 Iron Knob Street

Address line 2

Suburb *

Fyshwick

State *

ACT

Postcode *

2609

Contact name *

Schedule

Contact number *

Schedule

Email address *

Schedule@geocon.com.au
22(-)(ii)

Workers compensation

Is a compulsory Workers Compensation Policy maintained? *

- Yes
- No
- Not applicable

Details of inspection

Site/Workplace address

Same as registered address

Address line 1 *

Block 15 Section 5

Address line 2

Suburb *

PHILLIP

State

ACT

Postcode *

2606

Notification of entry to (as required by s164) *

- PCBU
- Manager
- Supervisor
- HSR
- Other
- N/A

Inspector notes

Attended location inspection undertaken as a result of the inspection the following items were discussed;

* Power cable supplying feed to tower crane mechanical protection- previously Inspector Mason has attended site in relation to and incident involving pylon impacting tower section of the tower crane where concerns were noted with the power cable. Inspector Mason will contact Titan Cranes to discuss the matter.

* Falls from heights form deck around tower crane tower a significant gap between form deck and structure was present whilst on site matter rectified.

* Inspection of eastern jump form no first aid kit present, also discussed access egress in and out of the jump form for emergency evacuation. Discussion had in regards to minimum MPA strength of concrete before form structure is raised given top edge of formed concrete is utilised to raise jacks. It was also discussed in regards to the mounting of the concrete safety boom on top of the jump forms.

* Discussion had in regards to the Doka flex formwork systems being utilised on various areas of the project in comparison to use of conventional formwork system benefit of the Doka system being less exposure to working at height. However system is limited in regards to the height in which the system can be incorporated therefore conventional formwork is used as such the risk of falls from heights needs extra controls.

* Installation of kickboard required on leading edge form deck above ramp into lower basement work area.

* Discussion had over the use of screens for managing the risk of falls.

Further action

Further action required? *

Yes No

Previous notice/s issued?

Yes No

Finalisation details

Photos

Other attachments (documents)

WPV for asbestos related issue *

Yes No

Industry group *

Construction

Compliant at initial proactive inspection? *

Yes No

Time finished *

12:15

Disclaimer:

The issues identified during this Inspection are only indicative of compliance with the Work Health and Safety Act 2011, Work Health and Safety Regulation 2011, Dangerous Substance Act 2004 and Workers Compensation Act 1951 on the date of the Inspection. If compliance is identified during this Inspection, it does not remove the obligation of any person to comply with any further requirement of the above mentioned Acts and Regulations.

Lead inspector email address *

A an.Chipperfield@act.gov.au

How many other email addresses would you like to send this to? *

1

Email 1 *

Schedule 2 2(a)(ii) @geocon.com.au

Privacy notice

The information collected for the purpose of the Work Health and Safety Act 2011 and is in accordance with the Information Privacy Act 2014. WorkSafe ACT prevents any unreasonable intrusion into person's privacy in accordance with the Privacy Act 1988 (C'W th) and Information Privacy Act 2014. WorkSafe ACT provides identifiable information which can be disclosed to other law enforcement agencies and authorised organisations that have legal authority to request information under prescribed circumstances.

Initial information

Type of report *

Workp ace Visit

Inspector ID *

P05757

Inspection number

WPV-P05757-VMF6MR

Event number

191211-000393

Lead inspector *

A an Chipperfie d

Is there any accompanying inspectors *

Yes

No

Item Number 1

Accompanying inspector/Other *

Tekoa Dawson

Date *

10 Dec 2019

Time commenced *

9:00

Type of WPV *

Proactive

Reactive

Purpose of WPV *

N/A

Legis ation *

Work Hea th and Safety Act 2011

Is this a joint inspection? *

Yes

No

Name of individua or registered company *

Geocon Constructors Pty Ltd

ABN

86126126850

ACN

Business or trading name (if different)

Registered company address

Address line 1 *

Unit 18, Level 1, 24 Iron Knob Street

Address line 2

Suburb *

Fyshwick

State *

ACT

Postcode *

2609

Contact name *

Schedule

Contact number *

Schedule

Email address *

Schedule
22(a)(ii)@geocon.com.au

Workers compensation

Is a compulsory Workers Compensation Policy maintained? *

- Yes
- No
- Not applicable

Details of inspection

Site/Workplace address

Same as registered address

Address line 1 *

Block 15 Section 5

Address line 2

Suburb *

PHILLIP

State

ACT

Postcode *

2606

Notification of entry to (as required by s164) *

- PCBU
- Manager
- Supervisor
- HSR
- Other
- N/A

Inspector notes

Attended site where a proactive inspection was undertaken as a result of the inspection the following items were identified as requiring rectification:

- * Concrete agitator delivery drivers not using PPE- hearing protection.
- * Electrical leads not on lead stands or insulated hooks various locations.
- * Basement temporary propping with temporary power supply attached leading to electrical boards not secured or mechanical protection in place.
- * Basement stair gaps between sections of metal hand rail.
- * Kickboards basement stairs where objects can roll from one level to another.
- * Zone 1 level 2 storage of window frames not secured adequately to stabilize.
- * Electrical distribution boards identified that access light in corridors and at boards is not connected to battery backup.
- * Multi decks engineer sign off has been obtained for propping configuration.
- * Level 2 zone 3&4 housekeeping.
- * Core B stair penetration covers.
- * Core A stair concrete delivery pipes mounting brackets noted on only one fixing per side.
- * Core A level 2 exclusion zone not in place for formwork activities.
- * Level 3 stacking of form bearers in an insecure manner.
- * Kickboards ab edge south level 3 south adjacent to A imac cage doors.
- * Installation of temporary tie outs on nominated floors.
- * Level 3 formwork stripping use of bolts in props/frames to support semi suspended form deck, no exclusion zone in place for stripping activities.

Further action

Further action required? *

- Yes** **No**

Further inspections required? *

- Yes** **No**

Selecting Yes to the above question will cause a revisit task to be created in your task list

Notices issued *

- Yes** **No**

Previous notice/s issued?

- Yes** **No**

Finalisation details

Photos

Other attachments (documents)

WPV for asbestos related issue *

Yes No

Industry group *

Construction

Compliant at initial proactive inspection? *

Yes No

Time finished *

10:30

Disclaimer:

The issues identified during this Inspection are only indicative of compliance with the Work Health and Safety Act 2011, Work Health and Safety Regulation 2011, Dangerous Substance Act 2004 and Workers Compensation Act 1951 on the date of the Inspection. If compliance is identified during this Inspection, it does not remove the obligation of any person to comply with any further requirement of the above mentioned Acts and Regulations.

Lead inspector email address *

A an.Chipperfield@act.gov.au

How many other email addresses would you like to send this to? *

1

Email 1 *

Schedule 2 2(a)(ii) @geocon.com.au

Privacy notice

The information collected for the purpose of the Work Health and Safety Act 2011 and is in accordance with the Information Privacy Act 2014. WorkSafe ACT prevents any unreasonable intrusion into person's privacy in accordance with the Privacy Act 1988 (C'W th) and Information Privacy Act 2014. WorkSafe ACT provides identifiable information which can be disclosed to other law enforcement agencies and authorised organisations that have legal authority to request information under prescribed circumstances.

Initial information

Type of report *

Workp ace Visit

Inspector ID *

P05757

Inspection number

WPV-P05757-VMGOH2

Event number

191213-001441

Lead inspector *

A an Chipperfie d

Is there any accompanying inspectors *

Yes

No

Item Number 1

Accompanying inspector/Other *

Tekoa Dawson

Date *

13 Dec 2019

Time commenced *

9:00

Type of WPV *

Proactive

Reactive

Purpose of WPV *

Notifiab e incident

Legis ation *

Work Hea th and Safety Act 2011

Is this a joint inspection? *

Yes

No

Name of individua or registered company *

Geocon Constructors Pty Ltd

ABN

86126126850

ACN

Business or trading name (if different)

Registered company address

Address line 1 *

Unit 18, Level 1, 24 Iron Knob Street

Address line 2

Suburb *

Fyshwick

State *

ACT

Postcode *

2609

Contact name *

Schedule 2.2(a)(ii)

Contact number *

Schedule 2.2(a)(ii)

Email address *

Schedule 2.2(a)(ii)@geocon.com.au

Workers compensation

Is a compulsory Workers Compensation Policy maintained? *

- Yes
- No
- Not applicable

Details of inspection

Site/Workplace address

Same as registered address

Address line 1 *

Grand Central Towers Phillip

Address line 2

15 Bowes Street

Suburb *

PHILLIP

State

ACT

Postcode *

2606

Notification of entry to (as required by s164) *

- PCBU
- Manager
- Supervisor
- HSR
- Other
- N/A

Inspector notes

Attended site in relation to an incident that occurred on the 12 December 2019 where a formworker employed by ADCON has removed a temporary penetration cover on the form deck of level 7. In the process has stepped into the void approx 1600mm x 660mm and fell approx 3 metres to the next level sustaining injuries to his foot.

From information obtained and inspection of the area the following points were discussed;

- * Geo Con not immediately notified of the incident by Adcon
- * Incident location not preserved or maintained.
- * Penetration cover not marked to advise the presence of the void.
- * Injured worker was detasked from constructing stair form to infilling voids in the form deck by Adcon foreman.
- * Adcon Safe work method statement stipulates gaps greater than 400mm in formdeck infill bearers to be installed from below before access to the formdeck to infill gap.
- * It appears infill bearers not installed before accessing formdeck and removing penetration cover.

Other items discussed included:

- * Installation of safety screens and potential fall from heights whilst performing the task and on completion.
- * Review of Adcon safe work method statement(s)- SWMS found to be excessive in length and workers may not understand the contents of the SWMS relating to high risk construction work.
- * Emergency access to and from formdecks

*** Note: Follow up meeting held with representatives from Adcon where it was advised an Improvement Notice was to be issued in relation to reviewing the contents of the SWMS -Adcon. It was also advised that further inquiries to be made in relation to the incident by Work Safe Investigation Unit.

Improvement Notice IN-W-P05757-VMGG06-1

Further action

Further action required? *

- Yes No

Further inspections required? *

- Yes No

Selecting Yes to the above question will cause a revisit task to be created in your task list

Notices issued *

- Yes No

Previous notice/s issued?

- Yes No

Finalisation details

Photos

Other attachments (documents)

WPV for asbestos related issue *

Yes No

Industry group *

Construction

Time finished *

10:30

Disclaimer:

The issues identified during this Inspection are only indicative of compliance with the Work Health and Safety Act 2011, Work Health and Safety Regulation 2011, Dangerous Substance Act 2004 and Workers Compensation Act 1951 on the date of the Inspection. If compliance is identified during this Inspection, it does not remove the obligation of any person to comply with any further requirement of the above mentioned Acts and Regulations.

Lead inspector email address *

A an.Chipperfield@act.gov.au

How many other email addresses would you like to send this to? *

1

Email 1 *

Schedule 2 2(a)(ii) @geocon.com.au

Privacy notice

The information collected for the purpose of the Work Health and Safety Act 2011 and is in accordance with the Information Privacy Act 2014. WorkSafe ACT prevents any unreasonable intrusion into person's privacy in accordance with the Privacy Act 1988 (C'W th) and Information Privacy Act 2014. WorkSafe ACT provides identifiable information which can be disclosed to other law enforcement agencies and authorised organisations that have legal authority to request information under prescribed circumstances.

Notifiable Incident Report - Submission confirmation

our submission has been successful. Please keep a copy of this receipt for your records.

Date and time

Reference code

13 Dec 2019 1:20:31 PM

VRGNFVZ8

Access Canberra

GPO Box 158,
Canberra City ACT 2601

Phone: 02 6207 3000

Details of business or undertaking

Name of business or undertaking *

Geocon

Enter at least one phone number: *

Home phone number

62550430

Work phone number

Mobile number

Schedule
2.2(a)(ii)

Email

Schedule
2.2(a)(ii) @geocon.com.au

Address of business or undertaking

Address line 1 *

15 Bowes ST Woden

Address line 2

Suburb *

Woden

State *

ACT

Postcode *

2611

Details of the injured/involved person

Title

Given name *

Family name *

Schedule 2.2(a)(ii)

Date of birth *

Schedule 2.2(a)(ii)

Address of injured/involved person

Address line 1 *

Schedule 2.2(a)(ii)

Address line 2

Schedule 2.2(a)(ii)

Suburb *

State *

Postcode *

Schedule 2.2(a)(ii)

Job title/position *

Carpenter

Main duties *

Formwork

Enter at least one phone number: *

Home phone number

Work phone number

Mobile number

Schedule
2 2() (ii)

Email

Type of employment *

Full-time permanent

Type of worker *

Other (note: most employees will fall into this category)

Details of injury/illness/damage etc and any medical treatment *

orker fell from one level to another through a penetration in the deck.
orker has sustained 3 broken boned in his foot and some bruising

Details of the accident/incident

Date of the accident/incident *

12

12

2019

Time of the accident/incident *

03

40

PM

Were there any witnesses/other involved person? *

Yes

No

Describe the accident/incident *

orker was patching a formwork deck, worker removed a piece of ply that was screwed down and fell through the deck.

Name of supervisor or person in control of the site/location at the time of the accident/incident *

Schedule
2 2() (ii)

Address where accident/incident occurred

Same as business address

Where did the incident occur (e.g. plant room, roof) *

Level 7 Tower B

Environment and workplace conditions

Describe the workplace conditions at the time of the accident/incident (e.g. lighting, floor surface, weather, housekeeping etc) *

Good lighting, weather was fine approx 28 degrees with a light breeze. Houskeeing was OK.

Utilities

Does this NIR relate to damage to a Utilities Asset (e.g. power, gas, sewerage, water street lighting cable, etc.) *

Yes No

Task and supervision

What task was being performed when the accident/incident occurred? *

Formwork

Plant, equipment, tools, materials and substances

What plant/substances were being used? (provide details, e.g. model serial number, registration number etc) *

Meva formwork, form ply, hand tools

Risk assessment and where required for high risk construction work, SWMS

Was a risk assessment undertaken prior to commencing work? *

Yes No

Was a safe work method statement (SWMS) prepared if the work was high risk construction work? *

Yes No

Note: See the *Work Health and Safety Regulations 2011* s.299 for more information

Outcomes – please complete relevant parts of this section

Estimated date of resumption of work *

14

2

2020

Action that has been or will be taken to prevent recurrence *

Work has been stopped in the area. All areas are being made safe. Workers will be toolbox talked and SWMS will be reviewed before any further works continues with the MEVA system.

Name of person completing this form

Title

Mr

Given name *

Sch
d I

Family name *

Sched
I

Enter at least one phone number: *

Home phone number

Work phone number

Mobile number

Submitting this form will automatically create an account for you on the Access Canberra website. The account allows you to view, update or track your submission. Responses to your submission will be sent to your email address.

Email *

Job title/position *



ACT
Government

Access
Canberra.

WORKSAFE ACT

Improvement Notice

This is an Improvement Notice issued under section 191 of the Work Health and Safety Act 2011.

Issued by inspector

Inspector ID number

Notice Number

Alan Chipperfield

P05757

IN W P05757 VMGG06 1

To whom this notice is issued *

Company

Individual

Directorate

Name of registered company *

ACN

Adcon ACT Pty Ltd

Business or trading name (if different):

Registered company/business address

Address line 1 *

Level 1 33 Long and St

Address line 2

Suburb *

State *

Postcode *

Newstead

QLD

4006

Site/Workplace

Address line 1 *

15 Bowes Street

Address line 2

Suburb *

State

Postcode *

PHILLIP

ACT

2606

Method of service (s209)

Personal

Email/Fax

Served on *

Date of issue *

Schedule 2.2(a)(ii)

16 Dec 2019

Location with the address of workplace

The inspector believes the person

(a) has contravened a provision of this Act; or

(b) has contravened a provision in circumstances that make it likely that the contravention will continue or be repeated;

and

The provision that the inspector believes is being, or has been contravened is

Type of legislation *

Work Health and Safety Act 2011

Work Health and Safety Regulation 2011

Dangerous Substances Act 2004

Dangerous Substances (General) Regulation 2004

Section/s

299

Briefly, how the provision is being, or has been, contravened

As a result of an incident that occurred on the 12 December 2019 where a formworker has fallen approx 3m from the form deck to the level below through a penetration. An inspection undertaken at site on the 13 December 2019 identified concerns with the content of the Adcon Safe Work Method Statement(s) for performing high risk construction work

A safe work method statement must be set out and expressed in a way that is readily accessible and understandable to persons who use it

The date by which you are required to remedy the contravention or likely contravention

The day stated for compliance with the improvement notice must be reasonable in all circumstances

Date *

13 Jan 2020

This Notice may include directions concerning the measures to be taken to remedy the contravention or prevent the likely contravention, or matters or activities causing the contravention or likely contravention to which the notice relates. The inspector directs you to;

Undertake a review of relevant safe work method statements and make the necessary changes so the content of the safe work method statements are understandable to all workers who perform the required high risk construction.

The inspector recommends that you:

Improvement Notice issued under section 191 of the Work Health and Safety Act 2011 - further information

If you have any questions you may contact the inspector who issued this notice

Display of Notices

A person to whom a notice is issued must, as soon as possible, display a copy of the notice in a prominent place at or near the workplace, or part of the workplace, at which work is being carried out that is affected by the notice (s 210(1)) A person must not intentionally remove, destroy, damage or deface a notice displayed under s 210(1) while the notice is in force (s 210(2)) The maximum penalty for failing to comply with these provisions is \$5,000 for an individual or \$25,000 for a corporation

Compliance with direction or notice

The person to whom an improvement notice is issued must comply with the notice (s197) The maximum penalty for failing to comply with this requirement is \$100,000 for an individual or \$500,000 for a corporation

Regulator may carry out action

If a person to whom an improvement notice is issued fails to take reasonable steps to comply with the notice, and after giving written notice of this intention and the person's liability for the costs, the regulator (WorkSafe ACT) may take any remedial action that seems reasonable to make the workplace or situation safe (s 211) The regulator may then recover the reasonable costs of taking this remedial action (s213)

Contents of Notice

This Notice may state one or more of the following: (a) a workplace, or part of a workplace, at which the activity is not to be carried out; (b) anything that is not to be used in connection with the activity; (c) any procedure that is not to be followed in connection with the activity (s196(3))

Directions and recommendations

A direction may refer to a code of practice and may offer the person a choice of ways in which to remedy the contravention (s 204) An improvement notice may include recommendations that are not an offence to fail to comply with recommendations in a notice (s205)

Changes to notice by inspector

An inspector may make minor changes to a notice for clarification, to correct errors or references, or to reflect changes of address or other circumstances (s206)

Privacy statement

Access Canberra may obtain personal information about you in connection with this notice. The information may be collected and stored using the powers, and to carry out functions or activities, under the *Work Health and Safety Act 2011* and related work safety laws. Under that Act, the information can be disclosed to other ACT Government agencies or non government organisations, and other Australian work safety enforcement agencies.

Access Canberra is obliged to handle your information openly, transparently and in accordance with the Territory Privacy Principles set out in the *Information Privacy Act 2014*. For more information about how Access Canberra will collect, use, share, and store your personal information and how you can access and correct the information, please see the Access Canberra Privacy Statement at www.act.gov.au/privacy

Review of this *Work Health and Safety Act* notice

If you have any questions or need more information you may contact the inspector who issued this notice, or email worksafe@act.gov.au

You, or another person whose interests are affected by the decision, may apply for an internal review of the decision to issue this notice

A review may be sought within 14 days. You may also make an application for the reviewer to stay the operation of the improvement notice

Please ensure you include the notice number in your application for a review, together with the applicant's name and address, and the reason you are seeking the review

An application for a review can be made in writing to: The Director General, WorkSafe ACT, GPO Box 158 Canberra City ACT 2601 or by email: worksafe@act.gov.au

You may then seek a review of an internal reviewer's decision in the ACT Civil and Administrative Tribunal (ACAT). Information about that process can be found at www.acat.act.gov.au

The decision to issue this notice is also reviewable under the *Administrative Decisions (Judicial Review) Act 1989* on application to the ACT Supreme Court. Further, a person may make a complaint to the ACT Ombudsman about the issue of this notice

WorkSafe ACT contact details

PO Box 158, Canberra, ACT 2601

Email: worksafe@act.gov.au

Phone: (02) 6207 3000

Fax: (02) 6205 0336

Translating and Interpreting Service

Phone: 131 450

①

Schedule 2.2(a)(ii)

From: Schedule 2.2(a)(ii) @boral.com.au
Sent: Monday, 16 December 2019 8:13 AM
To: Schedule 2.2(a)(ii)
Cc:
Subject: Re: PPE on site at Grand Central Towers

Hi Schedule 2.2(a)(ii)

Thanks for your email. I have copied in Schedule 2.2(a)(ii) who is currently Boral's Production Manager for ACT so he is aware and can action a follow up with all our drivers.

Have a wonderful Christmas break!

Thanks, Schedule 2.2(a)(ii)

Schedule 2.2(a)(ii)

Account Manager - Concrete (ACT)

Telephone: Schedule
Mobile: Schedule
Fax: 02 6239 6032
Email: Schedule 2.2(a)(ii)@boral.com.au



Boral Concrete
Mugga Lane
Manuka ACT, Woden ACT 2609
www.boral.com.au

On Sat, 14 Dec 2019 at 08:01, Schedule 2.2(a)(ii) @geocon.com.au wrote:

Hi Schedule 2.2(a)(ii)

Just a note that we've had a few drivers not wearing hearing protection while dispensing concrete into the line pump. The pump is extremely noisy and if you could toolbox talk your operators about this that would be great.

Thanks heaps and I hope you enjoy your break over Christmas.

Regards,

Schedule 2.2(a)(ii) Safety and Quality Officer

Office: Unit 18 Level 1, 24 Iron Knob Street Fyshwick ACT 2609 | Postal: PO Box 5425, Kingston ACT 2604

P: 02 6258 0430 | F: 02 6241 2706 | E: Schedule 2.2(a)(ii)@geocon.com.au





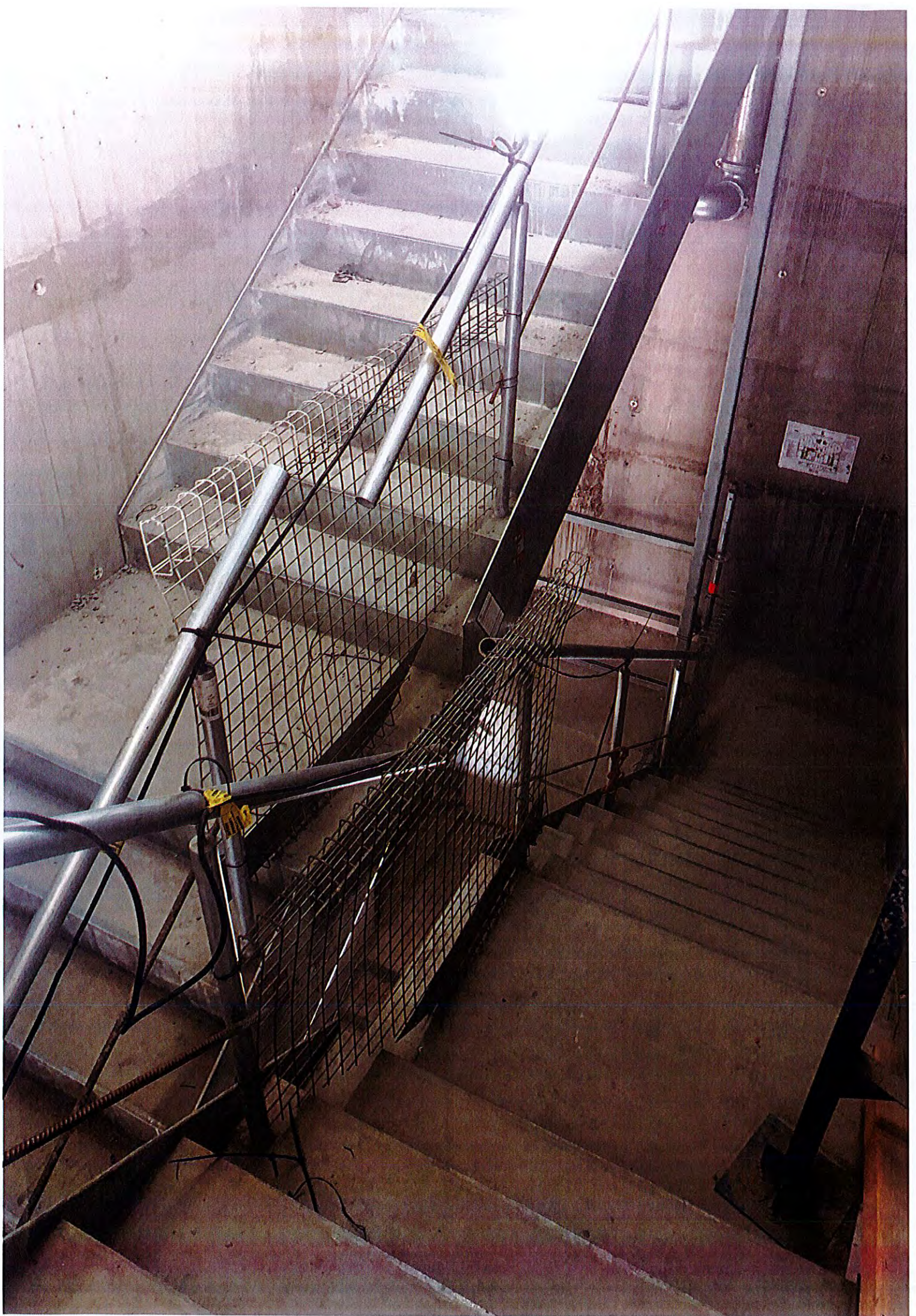



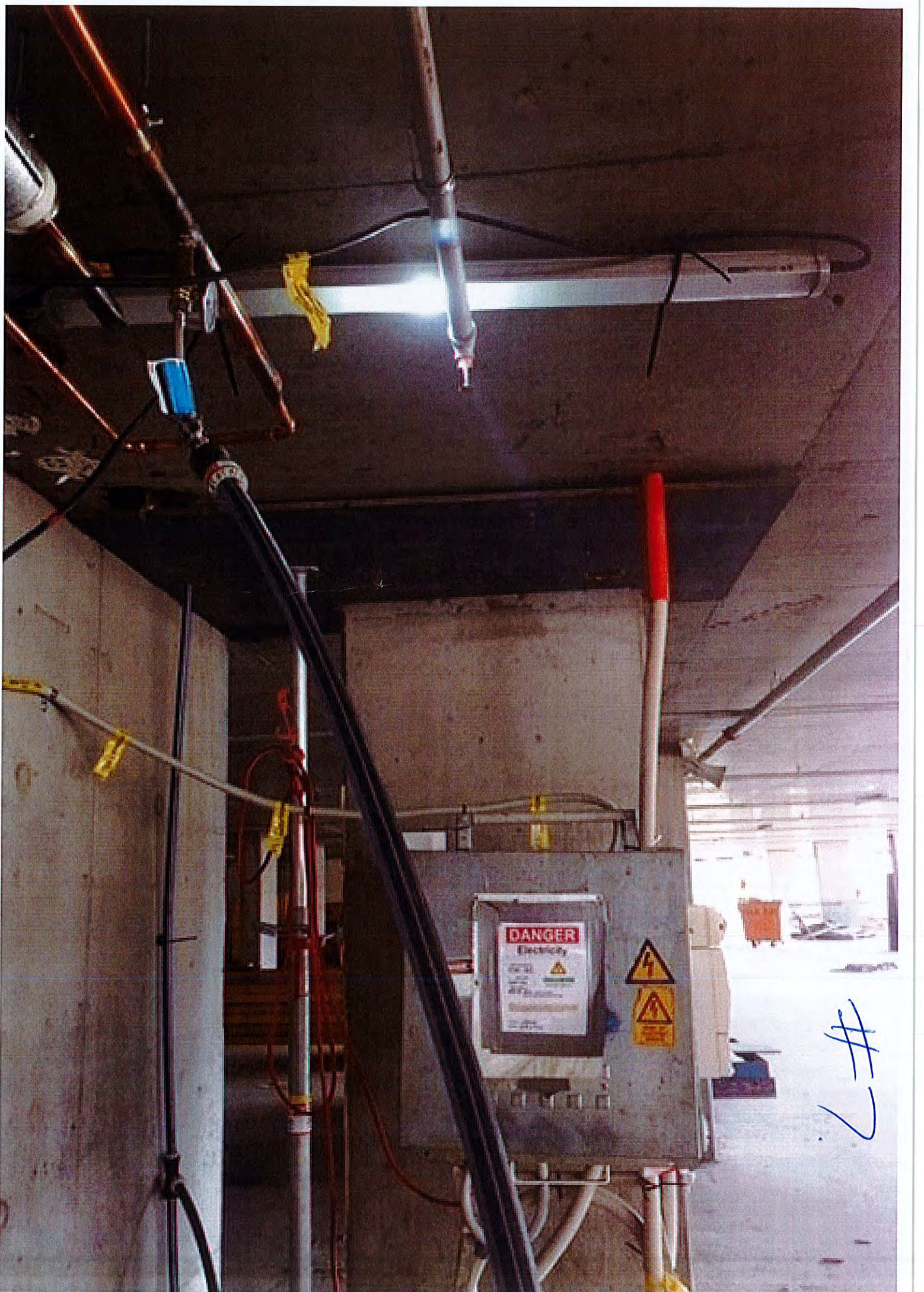

DANGER
Electricity



#7







DANGER
FORMWORK STRIPPING
IN PROGRESS
NO ENTRY

DANGER

DANGER





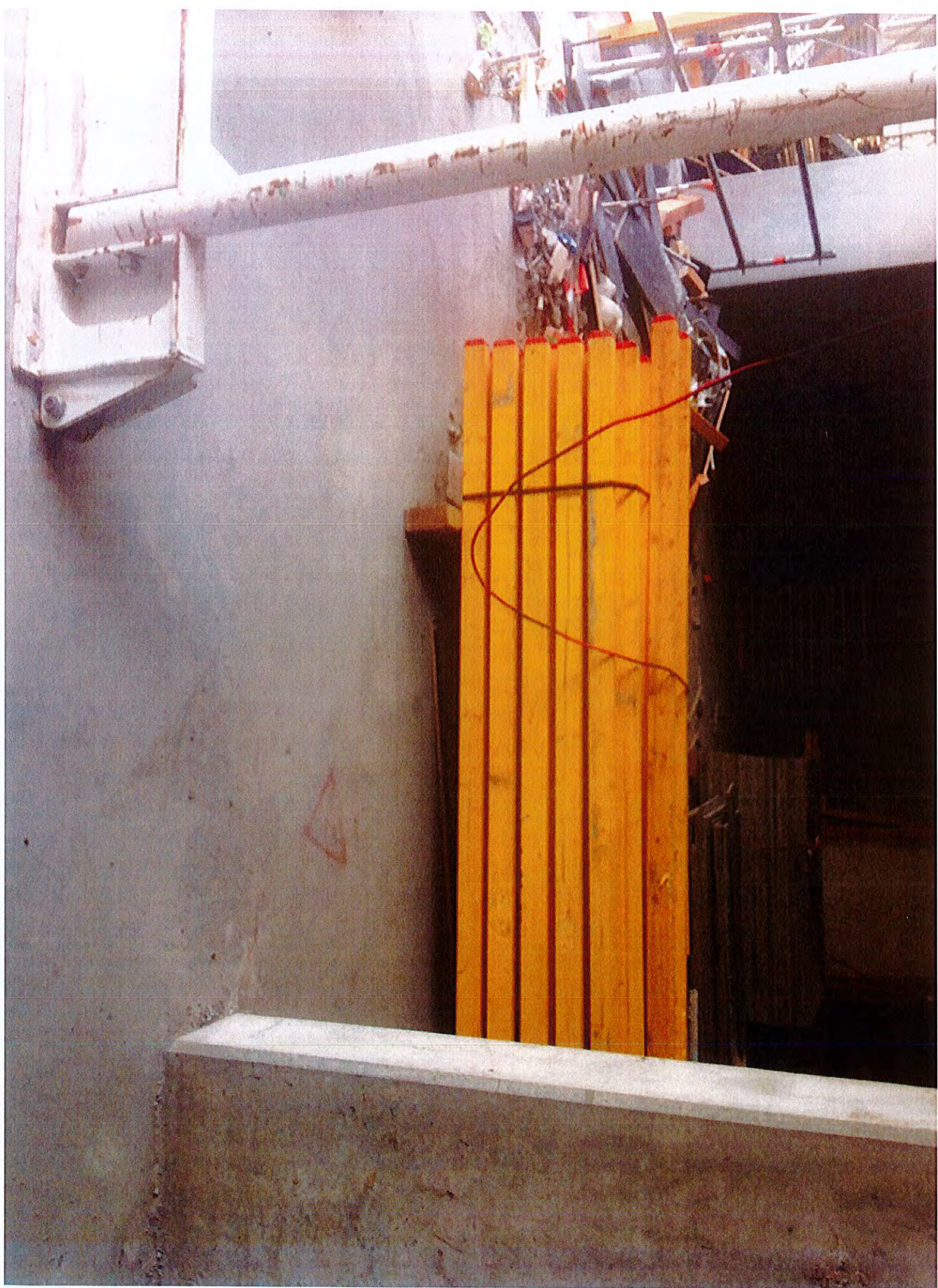

NOTE:
 - FOR EACH LOADING BAY POSITION ON PLAN, ASSUMED ONLY LOADING BAY AT ONE LEVEL IS OPERATIONAL AT ANY GIVEN TIME.
 - THE WORKING LOAD ON PROPS SPECIFIED IN THIS DOCUMENT IS CALCULATED BASED ON THE FOLLOWING:

1. LOADING BAY LOADS OF MULTIDECK 3.1 PLATFORM, BY DESIGN CONSTRUCT INDUSTRIES, DWG NO. DCI-20082015, DATED 20/08/2015.
2. PLATFORM SAFETY SCREEN NEEDLE LOADS, BY ADCON, DWG NO. SSC-GA-03 REV.0, DATED 15/04/19.

PTC DENOTES WORKING LOAD ON PROP EITHER SIDE OF LOADING BAY IS 75KN

SYMBOL DENOTES TEMPORARY BACK-PROPPING. REFER TO SECTIONS FOR EXTENT AND TO TEMPORARY WORKS ENGINEER'S DOCUMENTATIONS FOR DETAILS AND SPECIFICATION OF PROPPING DESIGN

ISSUE:
FOR CONSTRUCTION

PTC Consulting Engineers
 GCT - BLOCK 5 & 6, SECTION 35 PHILLIP, ACT
 LOADING BAY PROPPING REQUIREMENTS REV.2
 SK-337-STR-015 SHT 1 OF 5
 BY: JP DATE 03/10/19

OVERLAY OF GROUND FLOOR PLAN SHOWN IN RED

8

1	02/07/2019	ISSUED FOR CONSTRUCTION	RA	NS
0	15/04/2019	ISSUED FOR CONSTRUCTION	RA	NS
Rev	Date	Revision Detail	By	App

ADCON
 ENGINEERING
 your better structural solution

L1 - 33 LONGLAND ST, NEW STEAD
 QUEENSLAND 4006
 PH : 07 3118 1717 email: info@adconqld.com.au
 www.adconqld.com.au

CLIENT: GEOCON
 PROJECT: GRAND CENTRAL TOWERS
 BLOCK 5 & 6, SECTION 35
 PHILLIP, ACT

DRAWING TITLE: **PLATFORM SAFETY SCREENS
 LEVEL 2 TO LEVEL 5
 GENERAL PLAN**

DRAWN	RA	DATE	02/07/19	CHECKED	NS	DATE	02/07/19
DESIGNED	RA	DATE	02/07/19	CHECKED	NS	DATE	02/07/19
PROJECT NO.	18131			SCALE	NTS		
DRAWING NO.	SSC-L02-01			REV	1		

NOTE:
 - FOR EACH LOADING BAY POSITION ON PLAN, ASSUMED ONLY LOADING BAY AT ONE LEVEL IS OPERATIONAL AT ANY GIVEN TIME.
 - THE WORKING LOAD ON PROPS SPECIFIED IN THIS DOCUMENT IS CALCULATED BASED ON THE FOLLOWING:

1. LOADING BAY LOADS OF MULTIDECK 3.1 PLATFORM, BY DESIGN CONSTRUCT INDUSTRIES, DWG NO. DCI-20082015, DATED 20/08/2015.
2. PLATFORM SAFETY SCREEN NEEDLE LOADS, BY ADCON, DWG NO. SSC-GA-03 REV.0, DATED 15/04/19.

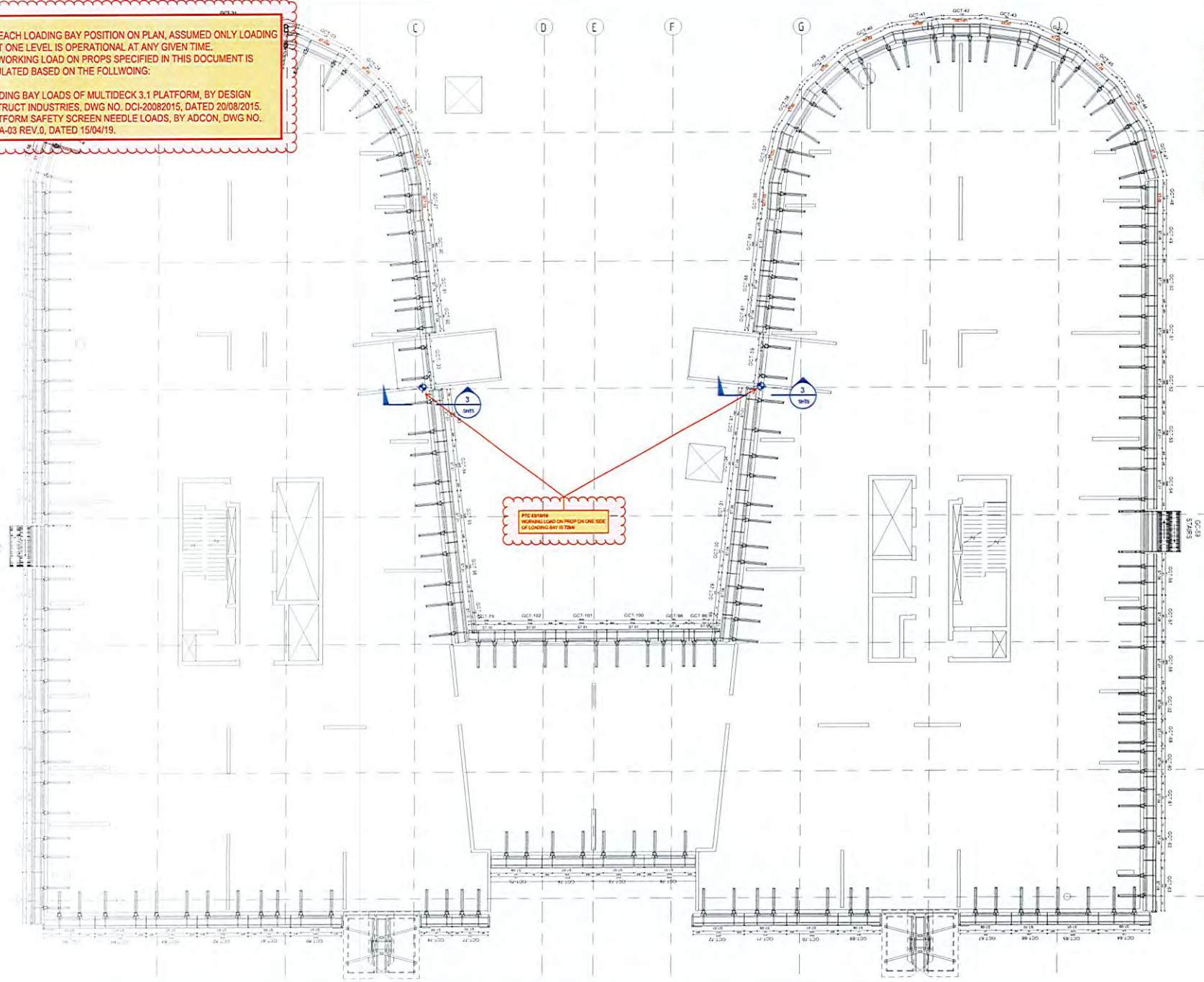

ISSUE:
FOR CONSTRUCTION

PTC Consulting Engineers
 GCT - BLOCK 5 & 6, SECTION 35 PHILLIP,
 ACT
 LOADING BAY PROPPING REQUIREMENTS
 REV.2
 SK-337-STR-015 SHT 2 OF 5
 BY: JP DATE 03/10/19

Rev	Date	Revision Detail	RA	NS
1	02/07/2019	ISSUED FOR CONSTRUCTION	RA	NS
0	15/04/2019	ISSUED FOR CONSTRUCTION	RA	NS

ADCON
 ENGINEERING
 your better structural solution

L1 - 33 LONGLAND ST, NEW STEAD
 QUEENSLAND 4006
 PH : 07 3118 1717 email: info@adconqld.com.au
 www.adconqld.com.au

CLIENT: **GEOCON**

PROJECT: **GRAND CENTRAL TOWERS
 BLOCK 5 & 6, SECTION 35
 PHILLIP, ACT**

DRAWING TITLE: **PLATFORM SAFETY SCREENS
 LEVEL 7 TO LEVEL 15
 GENERAL PLAN**

DRAWN	DATE	CHECKED	DATE
RA	02/07/19	NS	02/07/19
DESIGNED	DATE	CHECKED	DATE
RA	02/07/19	NS	02/07/19

PROJECT No.	SCALE
18131	NTS

DRAWING No.	REV
SSC-L07-01	1

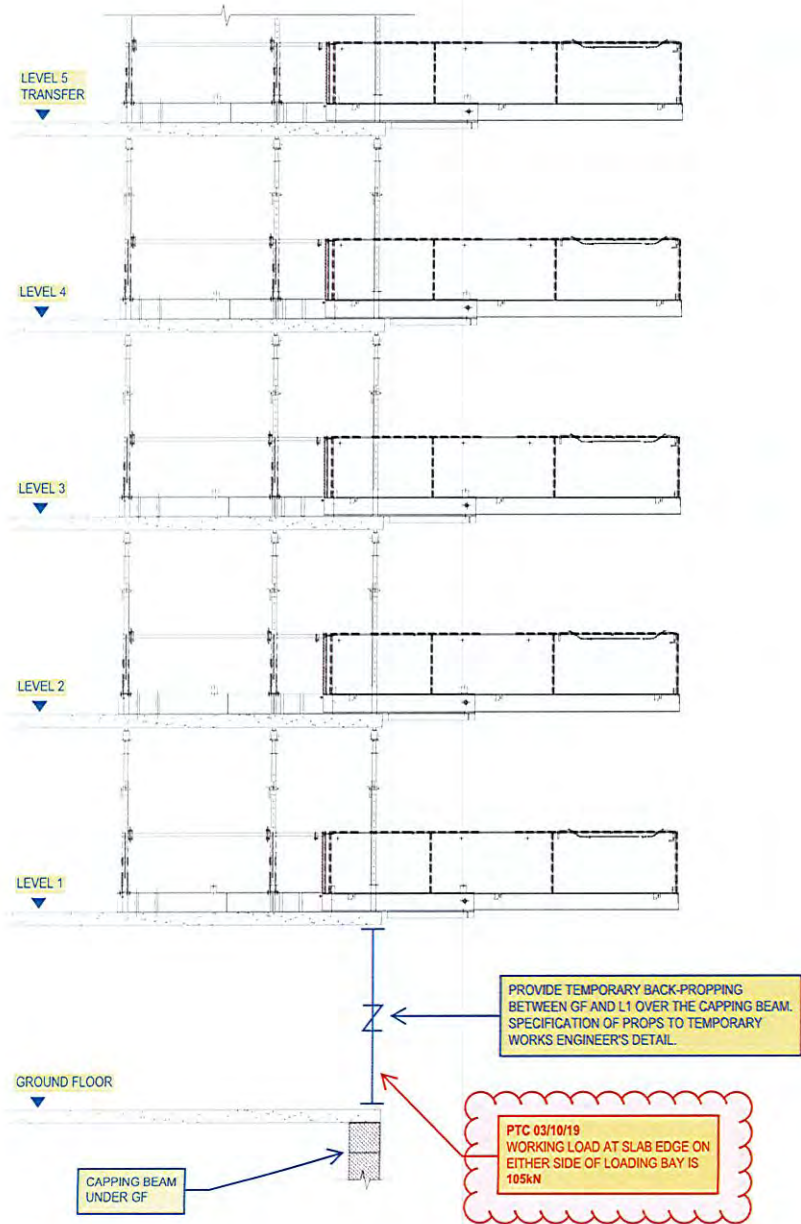

SECTION 1
LOADING BAYS INSTALLED ON L1 TO L4

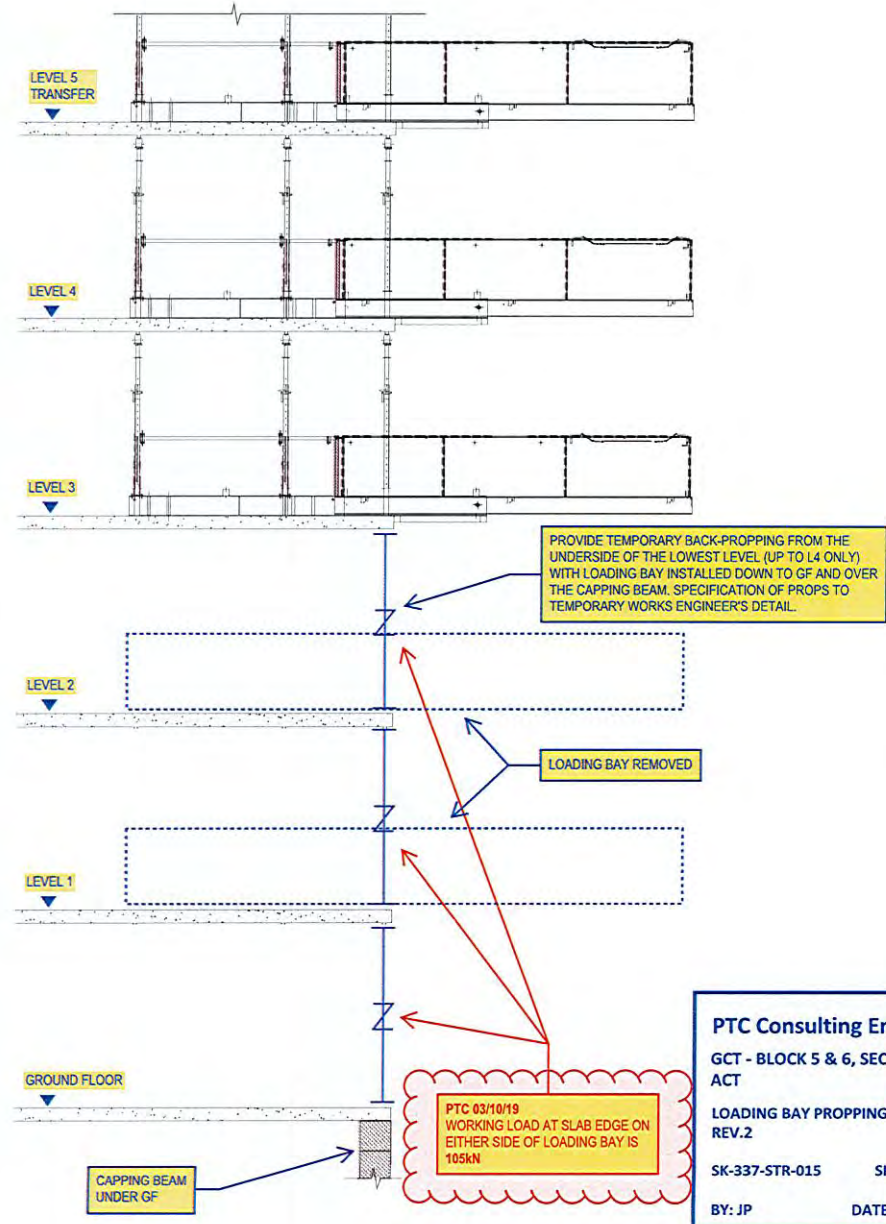

SECTION 1
LOADING BAYS REMOVED AT LOWER LEVELS

PTC Consulting Engineers
 GCT - BLOCK 5 & 6, SECTION 35 PHILLIP, ACT
 LOADING BAY PROPPING REQUIREMENTS
 REV.2
 SK-337-STR-015 SHT 3 OF 5
 BY: JP DATE 03/10/19

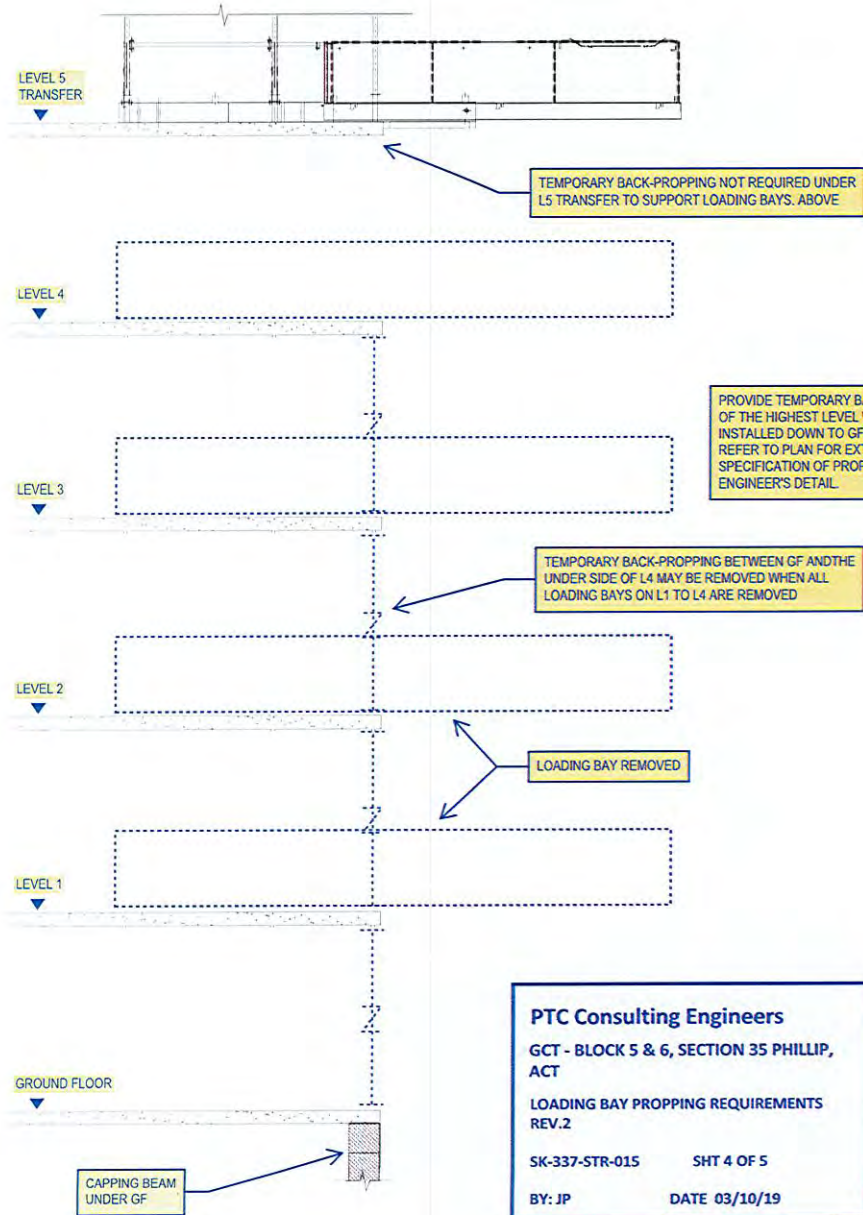

SECTION 1
LOADING BAYS REMOVED BETWEEN L1 TO L4

PTC Consulting Engineers
 GCT - BLOCK 5 & 6, SECTION 35 PHILLIP,
 ACT
 LOADING BAY PROPPING REQUIREMENTS
 REV.2
 SK-337-STR-015 SHT 4 OF 5
 BY: JP DATE 03/10/19

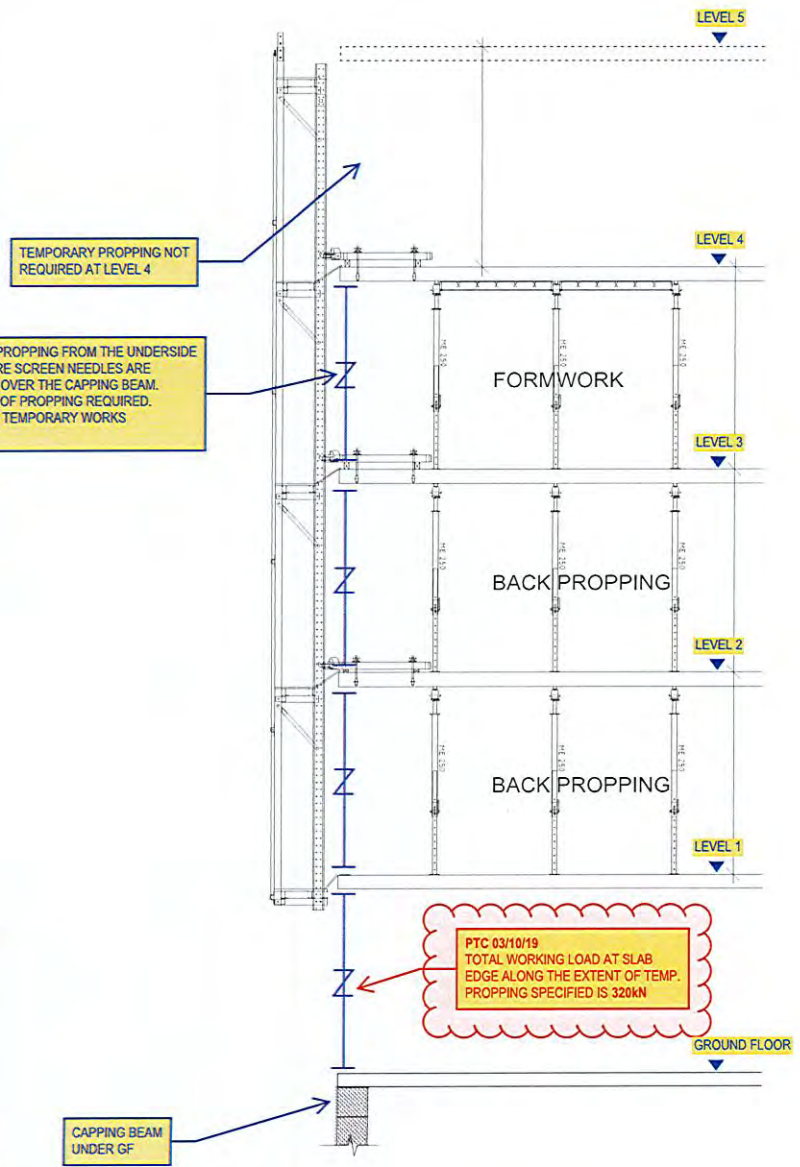

SECTION 2
TEMPORARY BACK-PROPPING BETWEEN GRID 6 & 7
SCREEN NEEDLES INSTALLED AT L4 AND BELOW

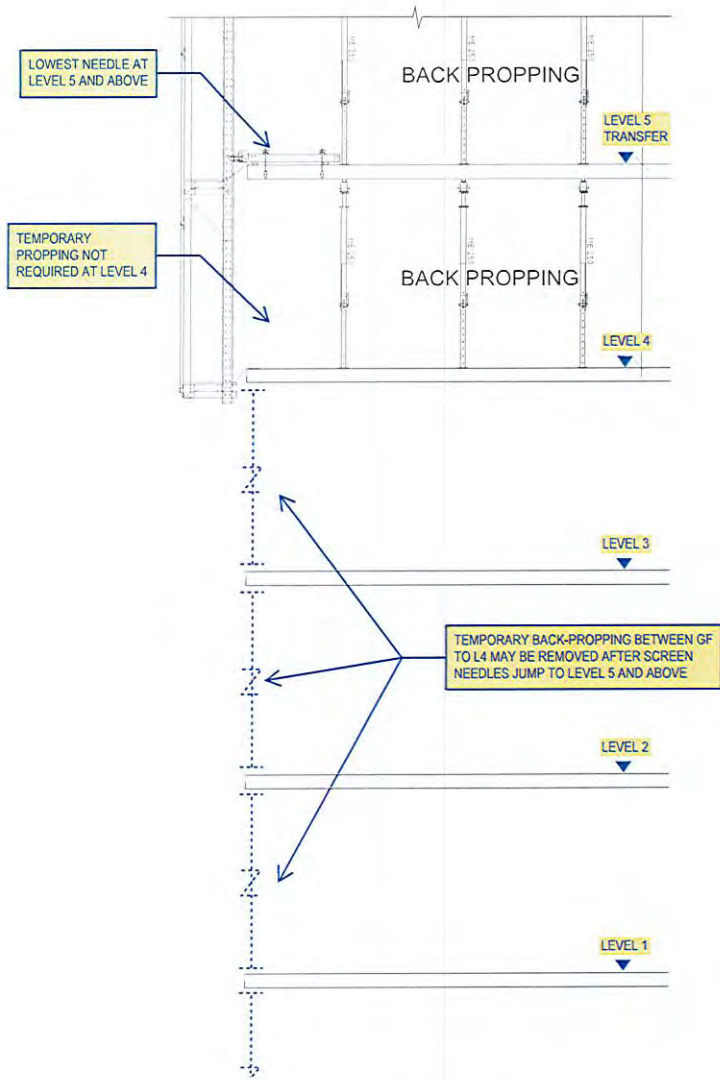

SECTION 2
TEMPORARY BACK-PROPPING BETWEEN GRID 6 & 7
SCREEN NEEDLES INSTALLED AT L5 AND ABOVE

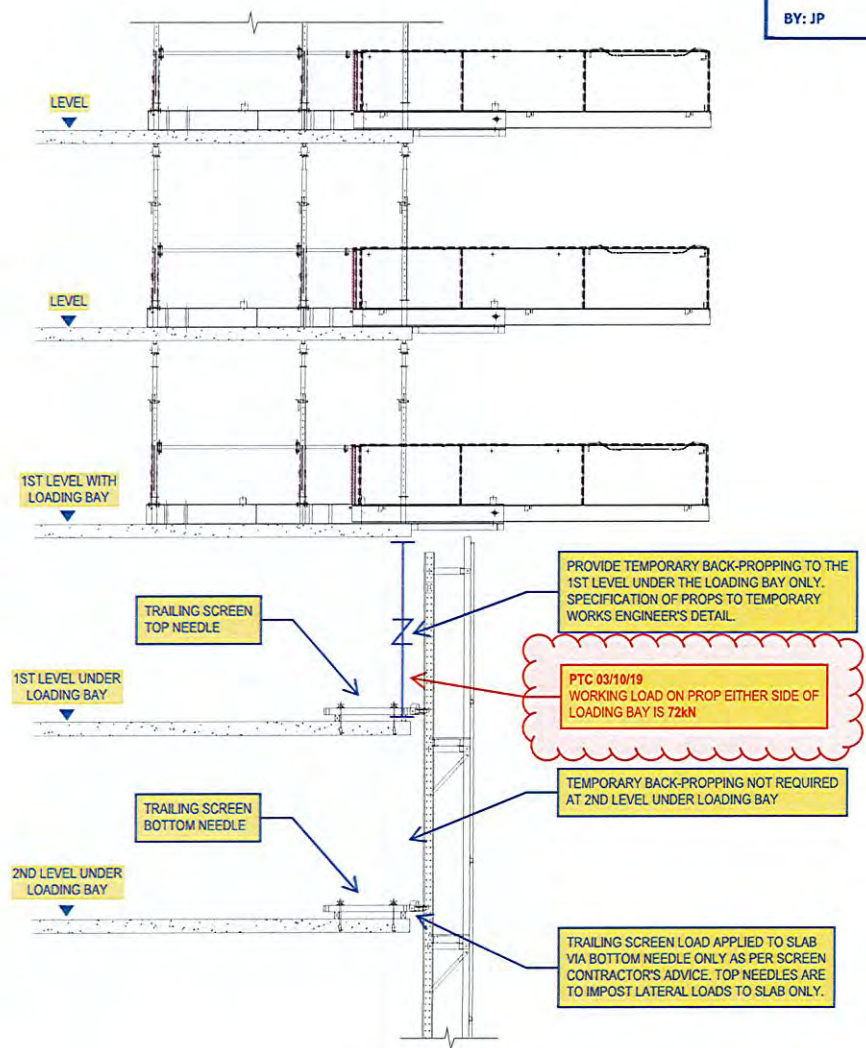

SECTION 3
TYPICAL BACK-PROPPING UNDER FIRST LOADING BAY

STRUCTURAL CERTIFICATION
A.M. Stoculka
 20/08/2015
 A.M. Stoculka M.Eng.Sc.(Syd Jni)
 M.I.E Aust C.P.Eng No. 3017

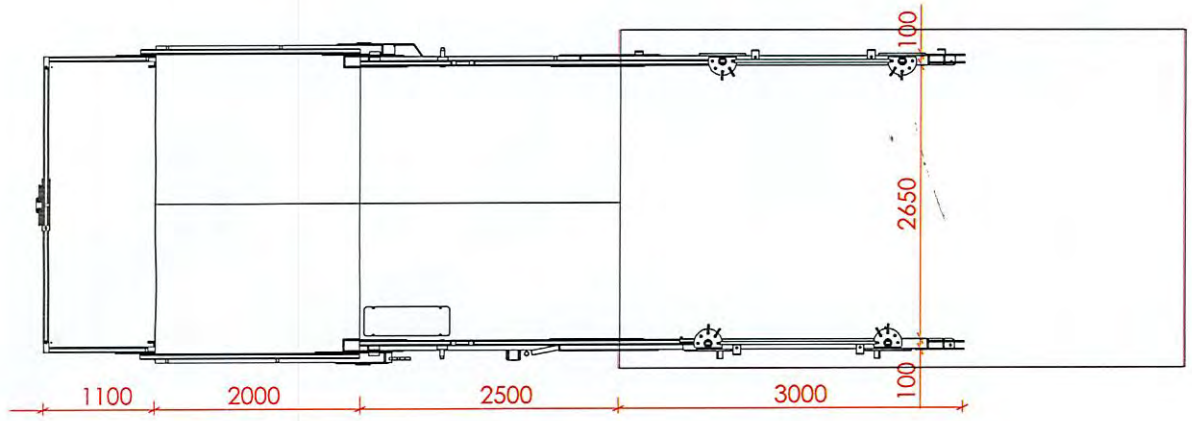

2000mm	6100KG
3000mm	4000KG
3500mm	3500KG
5200mm	2000KG

CAPACITY FROM SLAB

RC1	72.67KN
RS1	10.45KN
RS2	30.24KN

LOAD REACTIONS

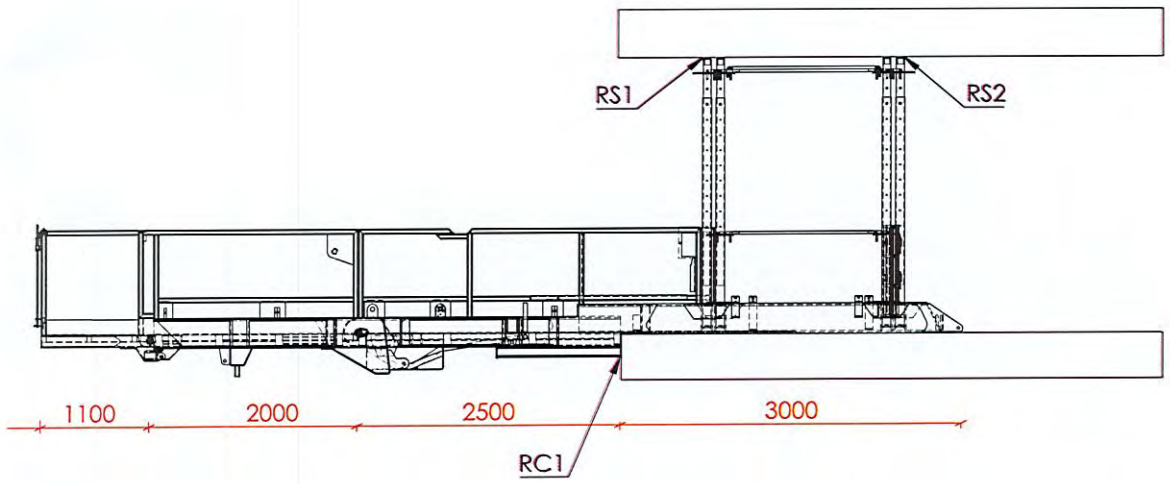

<p>DESIGN CONSTRUCT INDUSTRIES</p> <p>DCI Pty Ltd 98 TRALEE STREET HUME, A.C.T. 2620</p> <p>CONTACT DETAILS: PH: (02) 6260 1500 FAX: (02) 6260 1515 MOB: 0411 725 896 EMAIL: draft@conson.com WEB: www.conson.com</p> <p>ABN 50 117 543 129 ACN 117 543 129</p>	<p>MULTIDECK</p> <p>REACTION LOADS ON 3.1 PLATFORM</p>	<p>3.1 PLATFORM REACTION FORCES</p>	
		<p>AS SHOWN @A3</p>	<p>20/08/2015</p>
		<p>F.Sh</p>	<p>AS</p>
		<p>DCI-20082015</p>	<p>x/x</p>

THIS DRAWING AND ANY/ALL AMENDMENTS REMAIN THE PROPERTY OF DCI PTY LTD. DIMENSIONS OVEPPIDE ACTUAL SCALED DISTANCES - DO NOT SCALE FROM DRAWING



Project:	Grand Central Towers	Site:	Geocon			
Date:	12/12/19.	Shift:	Dayshift			
Scope of Work						
Agenda Items:	<input type="checkbox"/> Consultation	<input type="checkbox"/> Hazards	<input type="checkbox"/> Training	<input type="checkbox"/> Plant & Equip	<input type="checkbox"/> WHS Reports	<input type="checkbox"/> Audit Results
	<input type="checkbox"/> Client Info	<input type="checkbox"/> Feedback	<input type="checkbox"/> Performance	<input type="checkbox"/> Other		

Item No.	Item of Discussion	Comments
1	Fit for Work (all areas) <i>Supervisor visual assessment of employees, looking for signs of fatigue – observation / communicate to personnel that are they - alert / awake / work or non-work-related issues / understand the Pre-start meeting / SWMS's / Safe work procedures – Are They FIT for WORK – ARE WE OK?</i>	
	<i>Building A.</i>	<i>- Castles - Clean deck. - Stripping level 5/4/3.</i>
	<i>Building B.</i>	<i>- Deck - Screens - Stripping level 5.</i>
	<i>Link Jup A. Jup B.</i>	<i>- frames seal deck.</i>
<i>x</i>	<i>Stacking of data packs to be on beams or 2 timbers</i>	
<i>x</i>	<i>Execution rises to all stripping to be up and not come down until stripping is finished</i>	

Initial information

Type of report *

Inspector ID *

Inspection number

Lead inspector *

Is there any accompanying inspectors *

 Yes No

Item Number 1

Accompanying inspector/Other *

Date *

Name of individual or registered company *

Name of individual or registered company *

ABN

ACN

Business or trading name (if different)

Further action

Notices issued *

Yes

No

Type of notices *

Improvement

Prohibition

Other

Previous notice/s issued?

Yes

No



ACT
Government

Access
Canberra.

WORKSAFE ACT

Improvement Notice

This is an Improvement Notice issued under section 191 of the Work Health and Safety Act 2011.

Issued by inspector

Inspector ID number

Notice Number

Alan Chipperfield

P05757

IN W P05757 VMGG06 1

To whom this notice is issued *

Company

Individual

Directorate

Name of registered company *

ACN

Adcon ACT Pty Ltd

Business or trading name (if different):

Registered company/business address

Address line 1 *

Level 1 33 Long and St

Address line 2

Suburb *

State *

Postcode *

Newstead

QLD

4006

Site/Workplace

Address line 1 *

15 Bowes Street

Address line 2

Suburb *

State

Postcode *

PHILLIP

ACT

2606

Method of service (s209)

Personal

Email/Fax

Served on *

Date of issue *

Schedule

16 Dec 2019

Location with the address of workplace

The inspector believes the person

(a) has contravened a provision of the Act; or

(b) has contravened a provision in circumstances that make it likely that the contravention will continue or be repeated;

and

The provision that the inspector believes is being, or has been contravened is

Type of legislation *

Work Health and Safety Act 2011

Work Health and Safety Regulation 2011

Dangerous Substances Act 2004

Dangerous Substances (General) Regulation 2004

Section/s

299

Briefly, how the provision is being, or has been, contravened

As a result of an incident that occurred on the 12 December 2019 where a formworker has fallen approx 3m from the form deck to the level below through a penetration. An inspection undertaken at site on the 13 December 2019 identified concerns with the content of the Adcon Safe Work Method Statement(s) for performing high risk construction work

A safe work method statement must be set out and expressed in a way that is readily accessible and understandable to persons who use it

The date by which you are required to remedy the contravention or likely contravention

The day stated for compliance with the improvement notice must be reasonable in all circumstances

Date *

13 Jan 2020

This Notice may include directions concerning the measures to be taken to remedy the contravention or prevent the likely contravention, or matters or activities causing the contravention or likely contravention to which the notice relates. The inspector directs you to;

Undertake a review of relevant safe work method statements and make the necessary changes so the content of the safe work method statements are understandable to all workers who perform the required high risk construction.

The inspector recommends that you:

Improvement Notice issued under section 191 of the Work Health and Safety Act 2011 - further information

If you have any questions you may contact the inspector who issued this notice

Display of Notices

A person to whom a notice is issued must, as soon as possible, display a copy of the notice in a prominent place at or near the workplace, or part of the workplace, at which work is being carried out that is affected by the notice (s 210(1)) A person must not intentionally remove, destroy, damage or deface a notice displayed under s 210(1) while the notice is in force (s 210(2)) The maximum penalty for failing to comply with these provisions is \$5,000 for an individual or \$25,000 for a corporation

Compliance with direction or notice

The person to whom an improvement notice is issued must comply with the notice (s197) The maximum penalty for failing to comply with this requirement is \$100,000 for an individual or \$500,000 for a corporation

Regulator may carry out action

If a person to whom an improvement notice is issued fails to take reasonable steps to comply with the notice, and after giving written notice of this intention and the person's liability for the costs, the regulator (WorkSafe ACT) may take any remedial action that seems reasonable to make the workplace or situation safe (s 211) The regulator may then recover the reasonable costs of taking this remedial action (s213)

Contents of Notice

This Notice may state one or more of the following: (a) a workplace, or part of a workplace, at which the activity is not to be carried out; (b) anything that is not to be used in connection with the activity; (c) any procedure that is not to be followed in connection with the activity (s196(3))

Directions and recommendations

A direction may refer to a code of practice and may offer the person a choice of ways in which to remedy the contravention (s 204) An improvement notice may include recommendations that are not an offence to fail to comply with recommendations in a notice (s205)

Changes to notice by inspector

An inspector may make minor changes to a notice for clarification, to correct errors or references, or to reflect changes of address or other circumstances (s206)

Privacy statement

Access Canberra may obtain personal information about you in connection with this notice. The information may be collected and stored using the powers, and to carry out functions or activities, under the *Work Health and Safety Act 2011* and related work safety laws. Under that Act, the information can be disclosed to other ACT Government agencies or non government organisations, and other Australian work safety enforcement agencies.

Access Canberra is obliged to handle your information openly, transparently and in accordance with the Territory Privacy Principles set out in the *Information Privacy Act 2014*. For more information about how Access Canberra will collect, use, share, and store your personal information and how you can access and correct the information, please see the Access Canberra Privacy Statement at www.act.gov.au/privacy

Review of this *Work Health and Safety Act* notice

If you have any questions or need more information you may contact the inspector who issued this notice, or email worksafe@act.gov.au

You, or another person whose interests are affected by the decision, may apply for an internal review of the decision to issue this notice

A review may be sought within 14 days. You may also make an application for the reviewer to stay the operation of the improvement notice

Please ensure you include the notice number in your application for a review, together with the applicant's name and address, and the reason you are seeking the review

An application for a review can be made in writing to: The Director General, WorkSafe ACT, GPO Box 158 Canberra City ACT 2601 or by email: worksafe@act.gov.au

You may then seek a review of an internal reviewer's decision in the ACT Civil and Administrative Tribunal (ACAT). Information about that process can be found at www.acat.act.gov.au

The decision to issue this notice is also reviewable under the *Administrative Decisions (Judicial Review) Act 1989* on application to the ACT Supreme Court. Further, a person may make a complaint to the ACT Ombudsman about the issue of this notice

WorkSafe ACT contact details

PO Box 158, Canberra, ACT 2601

Email: worksafe@act.gov.au

Phone: (02) 6207 3000

Fax: (02) 6205 0336

Translating and Interpreting Service

Phone: 131 450

Finalisation details

Photos

Other attachments (documents)

Industry group *

Construction

Disclaimer:

The issues identified during this Inspection are only indicative of compliance with the Work Health and Safety Act 2011, Work Health and Safety Regulation 2011, Dangerous Substance Act 2004 and Workers Compensation Act 1951 on the date of the Inspection. If compliance is identified during this Inspection, it does not remove the obligation of any person to comply with any further requirement of the above mentioned Acts and Regulations.

Lead inspector email address *

A an.Chipperfield@act.gov.au

How many other email addresses would you like to send this to? *

1

Email 1 *

Sch
edu@adcongroun.com.au

Privacy notice

The information collected for the purpose of the Work Health and Safety Act 2011 and is in accordance with the Information Privacy Act 2014. WorkSafe ACT prevents any unreasonable intrusion into person's privacy in accordance with the Privacy Act 1988 (C'W th) and Information Privacy Act 2014. WorkSafe ACT provides identifiable information which can be disclosed to other law enforcement agencies and authorised organisations that have legal authority to request information under prescribed circumstances.
